

Dielectric®



RF Systems

Filters | Combiners | Components



Engineering Excellence since 1942

Table of Contents

Introduction	2
About Dielectric®	3
Standard Filters and Combiners	
Harmonic Filters	6
POWERLITE™ Filters	12
Bandpass Filters	32
Channel Combiners	48
Single Channel Combiners	58
Standard Coaxial and Waveguide (WR) Components	
Coaxial Rigid Line Components	61
Coaxial Patch Panels	79
Coaxial Switches	85
Waveguide (WR) Line Components	95
Waveguide (WR) Switches	103
Motorized Switch Controller	111
Miscellaneous	
Standard Tuning Lines	120
Standard Directional Couplers/Probes	121
Standard Reducers/Transitions	125
Standard Loads	129

Specifications are subject to change without notice.

For over 70 years, **Dielectric** has been a leader in the telecommunications industry with products and services such as:

- Antennas
- Towers
- Installation
- Maintenance
- Transmission Lines
- Combiners/Filters
- Custom RF Systems

Engineering Expertise

With more than 25 engineers on staff and industry experience ranging over a period of more than 15 years, the expertise at Dielectric far exceeds that of other telecommunication system providers. We plan to have our products in place and working for a very long time, and under the most severe environmental conditions around the world.

Full System Solutions

Since our inception, we have considered ourselves a solution oriented engineering company, priding ourselves on our depth of scientific experience and knowledge. Clients approach us with broadcast needs and we deliver full system solutions, jointly tasking with the client engineering staff to design the most technologically advanced systems in the world. We are one of the few companies who design and manufacture the full RF System from the transmitter output through to the antenna.

Dielectric's stock-in-trade is **RF Technology**. The application of this unique technology is in control of RF signal transmission from the generating transmitter to the target of the signal. This world-wide application includes radars, nuclear experimentation, industrial processing, commercial broadcasting, and wireless communications. RF Technology is a multi-discipline that combines electrical, electronic, mechanical and civil engineering fields which are reflected through all the company's products.

History

In the beginning, more than sixty five years ago, the company's founder, Dr. Charles D. Brown, engaged in research which resulted in the use of materials with dielectric characteristics, later utilized as insulators in coaxial transmission lines for the early radars during World War II. After the war, this military development like many others was applied in a civilian field: television broadcasting.

Early in its history, Dielectric developed pressurized dry air systems, for RF transmission systems' upgraded performance. Further to this, Dielectric developed the first dehydrator that successfully surpassed military shipboard requirements. This equipment was then used to pressurize the battleship radars during Admiral Bull Halsey's successful one year campaign for the Solomon Islands.

Facilities

The company is equipped for the design, development, manufacturing and testing of a wide range of products at its factory, which is located on 77 acres in Raymond, Maine. The factory is furnished for the machining, assembling, and finishing of materials used in its products, such as: copper, aluminum, stainless steel and dielectric materials. This facility, in addition to supporting model shop and product testing along with development laboratories occupies 120,000 sq. feet. Furthermore, the company has two complete antenna ranges, a transmission line optimization benchmark, a solid state transmitter and a thermal chamber for the research and development of new products.

Products

- Coaxial and waveguide configurations, as well as open wire, balanced line configuration.
- Motor and manually actuated switches, phase shifters, tuners, impedance matchers, and probe sections with directional couplers.
- Filters and combiners in coaxial and waveguide configurations for a variety of analog and digital telecommunication standards.
- Commercial broadcast and communication antennas.
- High power loads and associated cooling systems employing fluid heat transfer design.
- Dielectric products are used in RF systems, ranging in power of megawatts and frequency of microwaves.

Design Criteria

Dielectric assures top performance of its products by managing its design activities and manufacturing practices so that performance specifications are not only met, but often exceeded. Design criteria are sometimes affected by environmental conditions, such as rigorous climatic settings, along with many others including those encountered in nuclear research facilities. These are regularly met by Dielectric products around the world.

Documentation

The documentation Dielectric is called upon to supply to its customers, is always included with the service provided. Program Management, Equipment Installation Plans and Operating Manuals are offered as documentation for all the projects which use Dielectric equipment.

Field Services

We recognize the field service assistance as a valuable feature for our customers. Dielectric sends its field technicians to supervise the installation, start-up, and also for servicing its products at numerous sites throughout the world.

Quality Control

Dielectric is an ISO 9001 certified company that has procedures for controlling quality that far exceed the given requirements. These implemented procedures are used for all products and projects undertaken.

Packing and Shipping Facilities

Equipment, large or small, requires packaging to be appropriate to the product. Whether the company sends small, fragile components or delivers heavy equipment, it plans and packages so the equipment arrives on time on site and in the same condition as it left the factory.

- Are used between transmitter output and antenna system to suppressed the undesirable harmonic's products
- The wave guide harmonic filter's rejection is unaffected by input or output components
- The Dielectric coaxial and waveguide harmonic filters are offered for all applications in VHF & UHF for standard channel bandwidths 6, 7 and 8 MHz and for custom bandwidths requirements

VHF Harmonic Filters

Frequency	Average Power Handling	Application
54-88 MHz	≤ 10 kW	ATV/DTV/MM
174-230 MHz	≤ 5 kW	ATV/DTV/MM
174-230 MHz	≤ 15 kW	ATV/DTV/MM

UHF Harmonic Filters

Frequency	Average Power Handling	Application
554-806 MHz	≤ 1.5 kW	ATV/DTV/MM
470-806 MHz	≤ 3.0 kW	ATV/DTV/MM
470-806 MHz	≤ 10 kW	ATV/DTV/MM
470-806 MHz	≤ 20 kW	ATV/DTV/MM
470-860 MHz	≤ 112.5 kW	ATV/DTV

Notes

ATV = Analog TV
 DTV = Digital TV
 MM = Mobile media

Specifications are subject to change without notice.

- Suitable for analog TV, digital TV and mobile media applications
- Indoor applications
- Low insertion loss figures
- High rejection of the harmonic products

Typical Specifications for 6 MHz TV Standard

Model Number	HVC1	HVC3
Frequency	174-230 MHz	174-230 MHz
Average Power Handling¹	≤ 5 kW	≤ 15 kW
VSWR	< 1.04	< 1.04
Insertion Loss	≤ 0.1 dB	≤ 0.1 dB

Rejection

2nd Order	> 40 dB	> 40 dB
3rd Order	> 40 dB	> 40 dB
Impedance	50 ohms	50 ohms
Connectors	1-5/8"	3-1/8"
Ambient Temperature	32°F (0°C) to 113°F (45°C)	32°F (0°C) to 113°F (45°C)
Storage Temperature	32°F (0°C) to 122°F (50°C)	32°F (0°C) to 122°F (50°C)
Ambient/ Storage Humidity	0-98%, non condensing	0-98%, non condensing
Material	Cu-outer Silver-plated inner	Cu-outer Silver-plated inner
Dimensions (L)	41" (1,041 mm)	63.64" (1,616 mm)
Weight	7.2 lbs (3.2 kg)	17.6 lbs (8 kg)
Max. Altitude²	10,000 feet (3,050 m)	10,000 feet (3,050 m)
Application	ATV/DTV/MM	ATV/DTV/MM

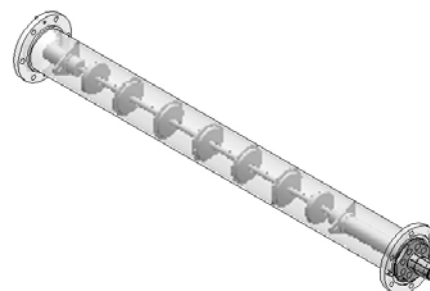

Notes

- 1) Ambient temperature of 104°F (40°C), sea level, 0 PSIG
- 2) For more than 5,000 feet (1,524 m), please contact the factory.

- Suitable for analog TV, digital TV and mobile media applications
- Indoor applications
- Low insertion loss figures
- High rejection of the harmonic products

Typical Specifications for 6 MHz TV Standard

Model Number	HURN-716	HUC1
Frequency¹	554-806 MHz	470-806 MHz
Average Power Handling²	≤ 1.5 kW	≤ 3 kW
VSWR	< 1.08	< 1.04
Insertion Loss	≤ 0.1 dB	≤ 0.1 dB

Rejection

2nd Order	> 75 dB	> 40 dB
3rd Order	> 45 dB	> 40 dB
Impedance	50 ohms	50 ohms
Connectors	"N" Female / 7/16" DIN	1-5/8" EIA
Ambient Temperature	5°F (-15°C) to 113°F (45°C)	32°F (0°C) to 113°F (45°C)
Storage Temperature	32°F (0°C) to 122°F (50°C)	32°F (0°C) to 122°F (50°C)
Ambient/ Storage Humidity	0-98%, non condensing	0-98%, non condensing
Material	Cu	Cu-outer Silver-plated inner
Dimensions (L)	7" x 4" x 1.75" (178 x 102 x 44.5 mm)	21" (534 mm)
Weight	2 lbs (0.9 kg)	4 lbs (1.8 kg)
Max. Altitude³	10,000 feet (3,050 m)	10,000 feet (3,050 m)
Application	ATV/DTV/MM	ATV/DTV/MM

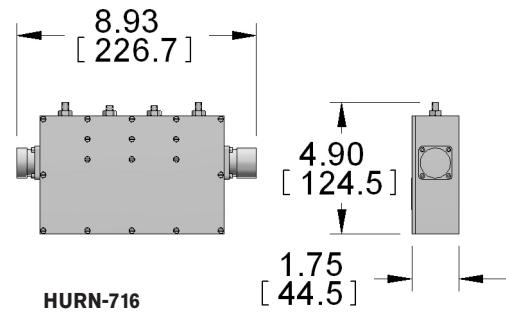

HURN-716

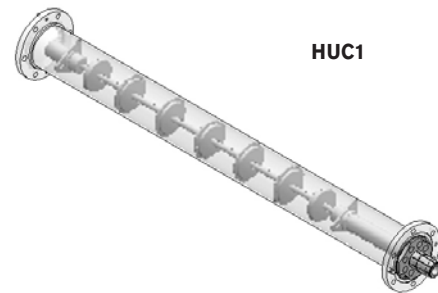
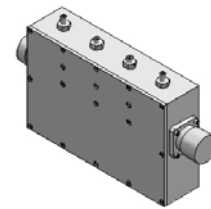

HUC1

Notes

- 1) For frequencies over 806 MHz, please contact the factory.
- 2) Ambient temperature of 104°F (40°C), sea level, 0 PSIG
- 3) For more than 5,000 feet (1,524 m), please contact the factory.

- Suitable for analog TV, digital TV and mobile media applications
- Indoor applications
- Low insertion loss figures
- High rejection of the harmonic products

Typical Specifications for 6 MHz TV Standard

Model Number	HUC3	HUC4
Frequency¹	470-806 MHz	470-806 MHz
Average Power Handling²	≤ 10 kW	≤ 20 kW
VSWR	< 1.04	< 1.05
Insertion Loss	≤ 0.1 dB	≤ 0.1 dB

Rejection

2nd Order	> 50 dB	> 40 dB
3rd Order	> 50 dB	> 40 dB
Impedance	50 ohms	50 ohms
Connectors	3-1/8" EIA	4-1/16" FLG
Ambient Temperature	32°F (0°C) to 113°F (45°C)	32°F (0°C) to 113°F (45°C)
Storage Temperature	32°F (0°C) to 122°F (50°C)	32°F (0°C) to 122°F (50°C)
Ambient/ Storage Humidity	0-98%, non condensing	0-98%, non condensing
Material	Cu-outer, Cu -capacitive sections, Silver-plated brass inductive sections	Cu-outer Silver-plated inner
Dimensions (L)	36" (914.4 mm)	20.5" (520.7 mm)
Weight	11.4 lbs (5.2 kg)	16 lbs (7.3 kg)
Max. Altitude³	10,000 feet (3,050 m)	10,000 feet (3,050 m)
Application	ATV/DTV/MM	ATV/DTV/MM

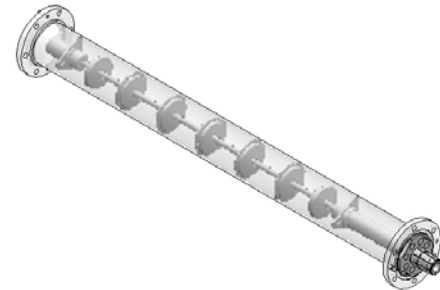

Notes

- 1) For frequencies over 806 MHz, please contact the factory.
- 2) Ambient temperature of 104°F (40°C), sea level, 0 PSIG
- 3) For more than 5,000 feet (1,524 m), please contact the factory.

- Suitable for analog TV, digital TV
- Indoor applications
- Low insertion loss figures
- High rejection of the harmonic products

Typical Specifications for 6 MHz TV Standard

Model Number	HUW18	HUW15	HUW11
Frequency	470-494 MHz	494-650 MHz	650-860 MHz
Average Power Handling¹	≤ 112.5 kW	≤ 112.5 kW	≤ 112.5 kW
VSWR	< 1.04	< 1.04	< 1.04
Insertion Loss	≤ 0.1 dB	≤ 0.1 dB	≤ 0.1 dB

Rejection

2nd Order	> 50 dB	> 50 dB	> 50 dB
3rd Order	> 50 dB	> 50 dB	> 50 dB
Connectors	WR 1800	WR 1500	WR 1150
Ambient Temperature	32°F (0°C) to 113°F (45°C)	32°F (0°C) to 113°F (45°C)	32°F (0°C) to 113°F (45°C)
Storage Temperature	32°F (0°C) to 122°F (50°C)	32°F (0°C) to 122°F (50°C)	32°F (0°C) to 122°F (50°C)
Ambient/ Storage Humidity	0-98%, non condensing	0-98%, non condensing	0-98%, non condensing
Material	Al	Al	Al
Dimensions (L)	98" (2,500 mm)	79" (2,007 mm)	57.5" (1,461 mm)
Weight	Contact the factory	Contact the factory	Contact the factory
Max. Altitude²	10,000 feet (3,050 m)	10,000 feet (3,050 m)	10,000 feet (3,050 m)
Application	ATV/DTV	ATV/DTV	ATV/DTV

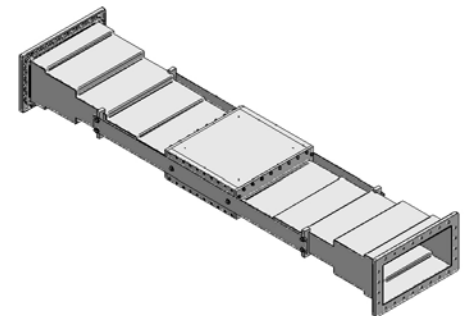
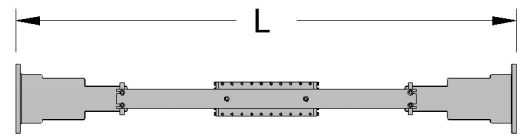
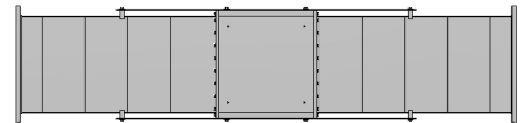

Notes

- 1) Ambient temperature of 104°F (40°C), sea level, 0 PSIG
- 2) For more than 5,000 feet (1,524 m), please contact the factory.

- For indoor applications
- For 6, 7 and 8 MHz channel bandwidths in analog TV, digital TV and mobile media applications
- DVB-T non-critical mask

Specifications

Model Number	UT6D2F-130		
Mask	DVB-T Non-Critical	DVB-T Non-Critical	DVB-T2/EXT Non-Critical
Maximum Input Power	130 Watts		
Frequency	470-862 MHz		
Channel BW	6 MHz	7 MHz	8 MHz
Insertion Loss			
Band Center	1.2 dB	1.0 dB	1.0 dB
Band Edge	2.9 dB (+/-2.86 MHz)	2.4 dB (+/-3.40 MHz)	2.0 dB (+/-3.80 MHz) 2.2 dB (+/-3.90 MHz) Ext.
Attenuation			
+/- 3.20/3.70/X.XX MHz	≥ 5.0 dB	≥ 3.5 dB	≥ NA
+/- 4.50/5.25/4.20 MHz	≥ 18 dB	≥ 18 dB	≥ 4.0 dB
+/- 9.0/10.5/6.0 MHz	≥ 40 dB	≥ 43 dB	≥ 18 dB
+/-12.0/12.0/12.0 MHz	≥ 55 dB	≥ 55 dB	≥ 44 dB
Group Delay Variation	< 400 nS	< 350 nS	< 350 nS
VSWR/RL	1.17:1/22.1 dB (+/-2.86 MHz)	1.17:1/22.1 dB (+/-3.40 MHz)	1.17:1/22.1 dB (+/-3.90 MHz)
Ambient Temperature	32°F(0°C) to 113°F(+45°C)		
Storage Temperature	14°F(-10°C) to 131°F(+55°C)		
Connectors In/Out	Type N Female		
Humidity	<95% Non-Condensing		
Altitude	3048 m (10000')		
Dimensions (LxWxH)	318mm X 115 mm X 204 mm (12.5"L X 4.5" W X 8" H)		
Weight	3kg / 6.6 lbs		
No Sections	6		
Transmission Zeros	4		

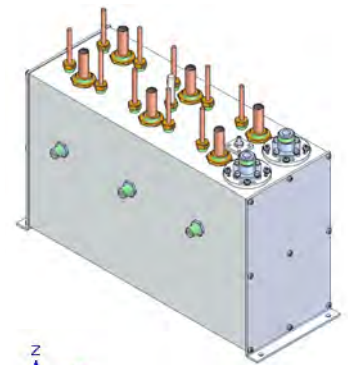

- For indoor applications
- For 6 MHz channel bandwidths in analog TV, digital TV and mobile media applications
- ATSC full mask, ATSC stringent mask, and ISDB-T non-critical mask

Specifications

Model Number	UT6E2F-130		
Mask	ATSC Full Mask	ATSC Stringent Mask	ISDB-T Non-Critical Mask
Maximum Input Power	130 Watts		
Frequency	470-806 MHz		
Channel BW	6 MHz		
Insertion Loss			
Band Center	1.2 dB	1.2 dB	1.2 dB
Band Edge	2.2 dB (+/-2.69 MHz)	2.2 dB (+/-2.69 MHz)	2.2 dB (+/-2.79 MHz)
Attenuation			
+/- 3.50 MHz	≥ 2.5 dB	≥ 5 dB	≥ NA
+/- 4.50 MHz	≥ 14 dB	≥ 23 dB	≥ 19 dB
+/- 6.0 MHz	≥ 33 dB	≥ 33 dB	≥ NA
+/- 9.0 MHz	≥ 64 dB	≥ NA	≥ 53 dB
Group Delay Variation	< 150 nS	< 200 nS	< 200 nS
VSWR/RL	1.17:1/22.1 dB (+/-2.69MHz)	1.17:1/22.1 dB (+/-2.69MHz)	1.17:1/22.1 dB (+/-2.79MHz)
Ambient Temperature	0-45 C (32-113 F)		
Storage Temperature	-10 – 55 C (14 – 131 F)		
Connectors In/Out	Type N Female		
Humidity	<95% Non-Condensing		
Altitude	3048 m (10000')		
Dimensions (LxWxH)	318mm X 115 mm X 204 mm (12.5"L X 4.5" W X 8" H)		
Weight	3kg / 6.6 lbs		
No Sections	6		
Transmission Zeros	2		

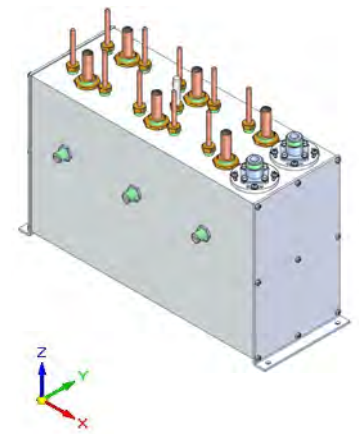

Dielectric POWERLITE™ Series 130W Tunable Bandpass Filter

- For indoor applications
- Temperature compensated
- For 6, 7 and 8 MHz channel bandwidths in analog TV, digital TV and mobile media applications
- DVB-T non-critical mask

Specifications

Model Number	UT8D2F-130		
Mask	DVB-T Critical	DVB-T Critical	DVB-T2/EXT Critical
Maximum Input Power	130 Watts		
Frequency	470-862 MHz		
Channel BW	6 MHz	7 MHz	8 MHz
Insertion Loss			
Band Center	1.6 dB	1.3 dB	1.2 dB
Band Edge	5.0 dB (+/-2.86 MHz)	4.8 dB (+/-3.40 MHz)	4.4 dB (+/-3.80 MHz) 4.9 dB (+/-3.90 MHz) Ext.
Attenuation			
+/- 3.20/3.70/X.XX MHz	≥ 15 dB	≥ 15 dB	≥ NA
+/- 4.50/5.25/4.20 MHz	≥ 28 dB	≥ 28 dB	≥ 15 dB
+/- 9.0/10.5/6.0 MHz	≥ 55 dB	≥ 53 dB	≥ 28 dB
+/-12.0/12.0/12.0 MHz	≥ 60 dB	≥ 60 dB	≥ 55 dB
Group Delay Variation	<700 nS	< 700 nS	< 700 nS
VSWR/RL	1.17:1/22.1 dB (+/-2.86 MHz)	1.17:1/22.1 dB (+/-3.40 MHz)	1.17:1/22.1 dB (+/-3.90 MHz)
Ambient Temperature	0-45 C (32-113 F)		
Storage Temperature	-10 – 55 C (14 – 131 F)		
Connectors In/Out	Type N Female		
Humidity	<95% Non-Condensing		
Altitude	3048 m (10000')		
Dimensions (LxWxH)	419mm X 115 mm X 204 mm (16.5"L X 4.5" W X 8" H)		
Weight	4kg / 8.5 lbs		
No Sections	8		
Transmission Zeros	4		

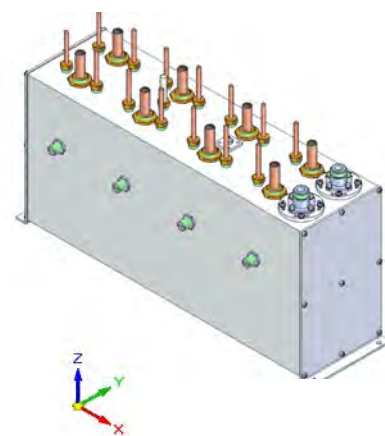

- For indoor applications
- For 6, 7 and 8 MHz channel bandwidths in analog TV, digital TV and mobile media applications
- DVB-T non-critical mask

Specifications

Model Number	UT6D3F-250		
Mask	DVB-T Non-Critical	DVB-T Non-Critical	DVB-T2/EXT Non-Critical
Maximum Input Power	250 Watts		
Frequency	470-862 MHz		
Channel BW	6 MHz	7 MHz	8 MHz
Insertion Loss			
Band Center	1.15 dB	1.0 dB	1.0dB
Band Edge	2.7 dB (+/-2.86 MHz)	2.2 dB (+/-3.40 MHz)	1.8 dB (+/-3.80 MHz) 2.0 dB (+/-3.90 MHz) Ext.
Attenuation			
+/- 3.20/3.70/X.XX MHz	≥ 3.0 dB	≥ 3.5 dB	≥ NA
+/- 4.50/5.25/4.20 MHz	≥ 18 dB	≥ 18 dB	≥ 4.0 dB
+/- 9.0/10.5/6.0 MHz	≥ 40 dB	≥ 43 dB	≥ 18 dB
+/-12.0/12.0/12.0 MHz	≥ 58 dB	≥ 55 dB	≥ 44 dB
Group Delay Variation	< 400 nS	< 350 nS	< 350 nS
VSWR/RL	1.17:1/22.1 dB (+/-2.86 MHz)	1.17:1/22.1 dB (+/-3.40 MHz)	1.17:1/22.1 dB (+/-3.90 MHz)
Ambient Temperature	0-45 C (32-113 F)		
Storage Temperature	-10 – 55 C (14 – 131 F)		
Connectors In/Out	Type N Female		
Humidity	<95% Non-Condensing		
Altitude	3048 m (10000')		
Dimensions (LxWxH)	318mm X 115 mm X 204 mm (12.5"L X 4.5" W X 8" H)		
Weight	3kg / 6.6 lbs		
No Sections	6		
Transmission Zeros	4		

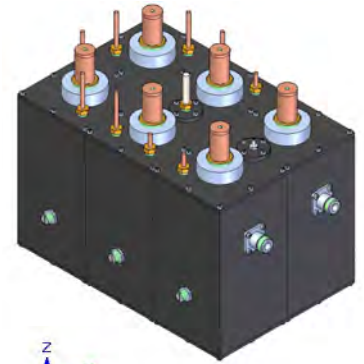

Dielectric POWERLITE™ Series 250W Tunable Bandpass Filter

- For indoor applications
- Temperature compensated
- For 6, 7 and 8 MHz channel bandwidths in analog TV, digital TV and mobile media applications
- DVB-T critical mask

Specifications

Model Number	UT8D3F-250		
Mask	DVB-T Critical	DVB-T Critical	DVB-T2/EXT Critical
Maximum Input Power	250 Watts		
Frequency	470-860 MHz		
Channel BW	6 MHz	7 MHz	8 MHz
Insertion Loss			
Band Center	1.1 dB	1.0 dB	1.0dB
Band Edge	4.1 dB (+/-2.86 MHz)	4.1 dB (+/-3.40 MHz)	3.0 dB (+/-3.80 MHz) 3.9 dB (+/-3.90 MHz) Ext.
Attenuation			
+/- 3.20/3.70/X.XX MHz	≥ 15 dB	≥ 15 dB	≥ NA
+/- 4.50/5.25/4.20 MHz	≥ 28 dB	≥ 28 dB	≥ 15 dB
+/- 9.0/10.5/6.0 MHz	≥ 55 dB	≥ 53 dB	≥ 28 dB
+/-12.0/12.0/12.0 MHz	≥ 60 dB	≥ 60 dB	≥ 55 dB
Group Delay Variation	<700 nS	< 700 nS	< 700 nS
VSWR/RL	1.17:1/22.1 dB (+/-2.86 MHz)	1.17:1/22.1 dB (+/-3.40 MHz)	1.17:1/22.1 dB (+/-3.90 MHz)
Ambient Temperature	0-45 C (32-113 F)		
Storage Temperature	-10 – 55 C (14 – 131 F)		
Connectors In/Out	Type N Female		
Humidity	<95% Non-Condensing		
Altitude	3048 m (10000')		
Dimensions (LxWxH)	381mm X 204 mm X 204 mm (15"L X 8.0" W X 8" H)		
Weight	6kg / 13 lbs		
No Sections	8		
Transmission Zeros	4		

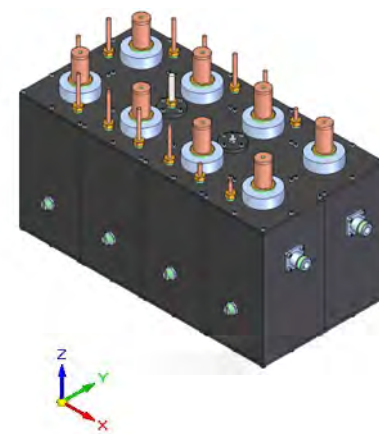

- For indoor applications
- For 6 MHz channel bandwidths in analog TV, digital TV and mobile media applications
- ATSC full mask, ATSC stringent mask, and ISDB-T non-critical mask

Specifications

Model Number	UT6E2F-250		
Mask	ATSC Full Mask	ATSC Stringent Mask	ISDB-T Non-Critical Mask
Maximum Input Power	250 Watts		
Frequency	470-806 MHz		
Channel BW	6 MHz		
Insertion Loss			
Band Center	1.15 dB	1.1 dB	1.1 dB
Band Edge	1.8 dB (+/-2.69 MHz)	1.8 dB (+/-2.69 MHz)	1.8 dB (+/-2.79 MHz)
Attenuation			
+/- 3.50 MHz	≥ 2.5 dB	≥ 5 dB	≥ NA
+/- 4.50 MHz	≥ 14 dB	≥ 23 dB	≥ 19 dB
+/- 6.0 MHz	≥ 33 dB	≥ 33 dB	≥ NA
+/- 9.0 MHz	≥ 64 dB	≥ NA	≥ 53 dB
Group Delay Variation	< 150 nS	< 200 nS	< 200 nS
VSWR/RL	1.17:1/22.1 dB (+/-2.69MHz)	1.17:1/22.1 dB (+/-2.69MHz)	1.17:1/22.1 dB (+/-2.79MHz)
Ambient Temperature	0-45 C (32-113 F)		
Storage Temperature	-10 – 55 C (14 – 131 F)		
Connectors In/Out	Type N Female		
Humidity	<95% Non-Condensing		
Altitude	3048 m (10000')		
Dimensions (LxWxH)	318mm X 115 mm X 204 mm (12.5"L X 4.5" W X 8" H)		
Weight	3kg / 6.6 lbs		
No Sections	6		
Transmission Zeros	2		

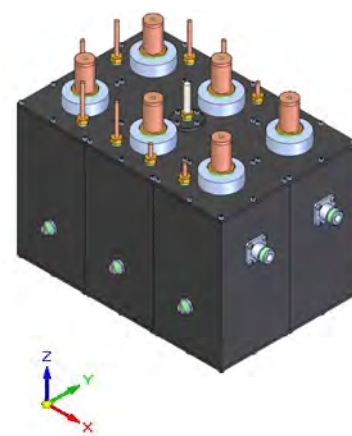

- For indoor applications
- Temperature compensated
- For 6, 7 and 8 MHz channel bandwidths in analog TV, digital TV and mobile media applications
- DVB-T non-critical mask

Specifications

Model Number	UT6D4F-600		
Mask	DVB-T Non-Critical	DVB-T Non-Critical	DVB-T2/EXT Non-Critical
Maximum Input Power	600 Watts		
Frequency	470-860 MHz		
Channel BW	6 MHz	7 MHz	8 MHz
Insertion Loss			
Band Center	1.2 dB	1.1 dB	1.1 dB
Band Edge	2.2 dB (+/-2.86 MHz)	2.0 dB (+/-3.40 MHz)	1.7 dB (+/-3.80 MHz) 1.9 dB (+/-3.90 MHz) Ext.
Attenuation			
+/- 3.20/3.70/X.XX MHz	≥ 3.0 dB	≥ 3.5 dB	≥ NA
+/- 4.50/5.25/4.20 MHz	≥ 18 dB	≥ 18 dB	≥ 4.0 dB
+/- 9.0/10.5/6.0 MHz	≥ 40 dB	≥ 43 dB	≥ 18 dB
+/-12.0/12.0/12.0 MHz	≥ 58 dB	≥ 55 dB	≥ 44 dB
Group Delay Variation	< 400 nS	< 350 nS	< 350 nS
VSWR/RL	1.15:1/23.1 dB (+/-2.86 MHz)	1.15:1/23.1 dB (+/-3.40 MHz)	1.15:1/23.1 dB (+/-3.90 MHz)
Ambient Temperature	0-45 C (32-113 F)		
Storage Temperature	-10 – 55 C (14 – 131 F)		
Connectors In/Out	7/16 DIN Female		
Humidity	<95% Non-Condensing		
Altitude	3048 m (10000')		
Dimensions (LxWxH)	370 mm X 254 mm X 204 mm (14.5"L X 10.0" W X 8" H)		
Weight	6kg / 13 lbs		
No Sections	6		
Transmission Zeros	4		

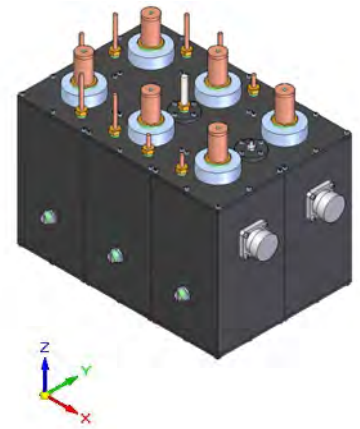

- For indoor applications
- For 6 MHz channel bandwidths in analog TV, digital TV and mobile media applications
- ATSC full mask, ATSC stringent mask, and ISDB-T non-critical mask

Specifications

Model Number	UT6E4F-600		
Mask	ATSC Full Mask	ATSC Stringent Mask	ISDB-T Non-Critical Mask
Maximum Input Power	600 Watts		
Frequency	470-806 MHz		
Channel BW	6 MHz		
Insertion Loss			
Band Center	1.2 dB	1.2 dB	1.2 dB
Band Edge	2.0 dB (+/-2.69 MHz)	2.0 dB (+/-2.69 MHz)	2.0 dB (+/-2.79 MHz)
Attenuation			
+/- 3.50 MHz	≥ 2.5 dB	≥ 5 dB	≥ NA
+/- 4.50 MHz	≥ 14 dB	≥ 23 dB	≥ 19 dB
+/- 6.0 MHz	≥ 33 dB	≥ 33 dB	≥ NA
+/- 9.0 MHz	≥ 64 dB	≥ NA	≥ 53 dB
Group Delay Variation	< 150 nS	< 200 nS	< 200 nS
VSWR/RL	1.15:1/23.1 dB (+/-2.69MHz)	1.15:1/23.1 dB (+/-2.69MHz)	1.15:1/23.1 dB (+/-2.79MHz)
Ambient Temperature	0-45 C (32-113 F)		
Storage Temperature	-10 – 55 C (14 – 131 F)		
Connectors In/Out	7/16 DIN Female		
Humidity	<95% Non-Condensing		
Altitude	3048 m (10000')		
Dimensions (LxWxH)	370 mm X 254 mm X 204 mm (14.5"L X 10.0" W X 8" H)		
Weight	6kg / 13 lbs		
No Sections	6		
Transmission Zeros	2		

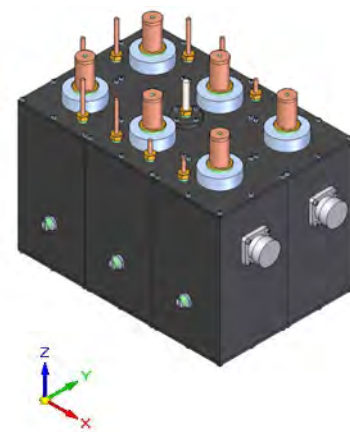

Dielectric POWERLITE™ Series 600W Tunable Bandpass Filter

- For indoor applications
- Temperature compensated
- For 6, 7 and 8 MHz channel bandwidths in analog TV, digital TV and mobile media applications
- DVB-T critical mask

Specifications

Model Number	UT8D4F-600		
Mask	DVB-T Critical	DVB-T Critical	DVB-T2/EXT Critical
Maximum Input Power	600 Watts		
Frequency	470-860 MHz		
Channel BW	6 MHz	7 MHz	8 MHz
Insertion Loss			
Band Center	1.4 dB	1.2 dB	1.1 dB
Band Edge	4.7 dB (+/-2.86 MHz)	4.4 dB (+/-3.40 MHz)	3.5 dB (+/-3.80 MHz) 4.1 dB (+/-3.90 MHz) Ext.
Attenuation			
+/- 3.20/3.70/X.XX MHz	≥ 15 dB	≥ 15 dB	≥ NA
+/- 4.50/5.25/4.20 MHz	≥ 28 dB	≥ 28 dB	≥ 15 dB
+/- 9.0/10.5/6.0 MHz	≥ 55 dB	≥ 53 dB	≥ 28 dB
+/-12.0/12.0/12.0 MHz	≥ 60 dB	≥ 60 dB	≥ 55 dB
Group Delay Variation	<700 nS	< 700 nS	< 700 nS
VSWR/RL	1.15:1/23.1 dB (+/-2.86 MHz)	1.15:1/23.1 dB (+/-3.40 MHz)	1.15:1/23.1 dB (+/-3.90 MHz)
Ambient Temperature	0-45 C (32-113 F)		
Storage Temperature	-10 – 55 C (14 – 131 F)		
Connectors In/Out	7/16 DIN Female		
Humidity	<95% Non-Condensing		
Altitude	3048 m (10000')		
Dimensions (LxWxH)	483 mm X 254 mm X 204 mm (19"L X 10.0" W X 8" H)		
Weight	7kg / 15 lbs		
No Sections	8		
Transmission Zeros	4		

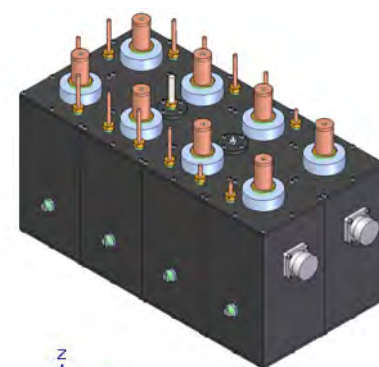

Dielectric **POWERLITE™** Series 600W Tunable Bandpass Filter

600 W rms, 6 Poles

- For indoor applications
- Temperature compensated
- 19" rack mountable
- For 6, 7 8 MHz channel bandwidths in analog TV, digital TV and mobile media applications

Specifications

Model Number	UTF6E-406	
Frequency	ATSC 6MHz 470-695 MHz	DVB-T 8MHz 470-862 MHz
Average Power Handling	≤ 600W DTW	
Type	REFLECTIVE	
Response Curve	STRINGENT	CRITICAL
VSWR	≤ 1.17	
Altitude ²	5,000 FT (1,524 M)	

Attenuation 6MHz ATSC (8MHz DVB-T)

F0	≤ 1.0 dB	≤ 1.0 dB
F0+/-2.69 MHz (3.80)	≥ 2.0 dB	≤ 3.50 dB
F0+/-3.5 MHz (4.20)	≥ 5 dB	≥ 15 dB
F0+/-4.5 MHz (—)	≥ 23 dB	N/A
F0+/-6.0 MHz (6.00)	≥ 33 dB	≥ 28 dB
F0+/-9.0 MHz (12.00)	≥ 40 dB	≥ 55 dB

Number Of Poles	6	8
Group Delay Variation ³	≤ 150 ns over passband	≤ 450 ns over passband
Connectors	7-16 DIN	
Ambient Temperature	32°F(0°C) to 113°F(+45°C)	
Storage Temperature	14°F(-10°C) to 122°F(+50°C)	
Ambient/Storage Humidity:	0-98%, non condensing	
Material	AL	
Dimensions (LxWxH) (Typical 6 Pole)	12.5"x4.5"x8"	
Weight	10 lbs.	

Notes

- 1) At ambient temperature 104°F (40°C), sea level, 0 PSIG
 - 2) Above 5,000 feet (1,524 m), please consult factory
 - 3) Group delay variation over the passband
- Floor mounting frame available, please contact factory.

Dielectric POWERLITE™ Series 1.5kW Tunable Bandpass Filter

- For indoor applications
- Temperature compensated
- For 6, 7 and 8 MHz channel bandwidths in analog TV, digital TV and mobile media applications
- DVB-T non-critical mask

Specifications

Model Number	UT6D7F-1.5K		
Mask	DVB-T Non-Critical	DVB-T Non-Critical	DVB-T2/EXT Non-Critical
Maximum Input Power	1500 Watts		
Frequency	470-860 MHz		
Channel BW	6 MHz	7 MHz	8 MHz
Insertion Loss			
Band Center	0.6 dB	0.5 dB	0.5 dB
Band Edge	1.1 dB (+/-2.86 MHz)	1.0 dB (+/-3.40 MHz)	1.0 dB (+/-3.80 MHz) 1.1 dB (+/-3.90 MHz) Ext.
Attenuation			
+/- 3.20/3.70/X.XX MHz	≥ 3.0 dB	≥ 3.5 dB	≥ NA
+/- 4.50/5.25/4.20 MHz	≥ 18 dB	≥ 18 dB	≥ 4.0 dB
+/- 9.0/10.5/ 6.0 MHz	≥ 40 dB	≥ 43 dB	≥ 18 dB
+/- 12.0/12.0/12.0 MHz	≥ 55 dB	≥ 55 dB	≥ 44 dB
Group Delay Variation	< 400 nS	< 350 nS	< 350 nS
VSWR/RL	1.12:1/24.9 dB (+/-2.86 MHz)	1.12:1/24.9 dB (+/-3.40 MHz)	1.12:1/24.9 dB (+/-3.90 MHz)
Ambient Temperature	0-45 C (32-113 F)		
Storage Temperature	-10 – 55 C (14 – 131 F)		
Connectors In/Out	1 5/8 EIA		
Humidity	<95% Non-Condensing		
Altitude	3048 m (10000')		
Dimensions (LxWxH)	597mm X 381 mm X 178 mm (23.25"L X 15" W X 7" H)		
Weight	20.5kg / 45 lbs		
No Sections	6		
Transmission Zeros	4		



Dielectric POWERLITE™ Series 1.5kW Tunable Bandpass Filter

- For indoor applications
- For 6 MHz channel bandwidths in analog TV, digital TV and mobile media applications
- ATSC full mask, ATSC stringent mask, and ISDB-T non-critical mask

Specifications

Model Number	UT6E7F-1.5K		
Mask	ATSC Full Mask	ATSC Stringent Mask	ISDB-T Non-Critical Mask
Maximum Input Power	1500 Watts		
Frequency	470-806 MHz		
Channel BW	6 MHz		
Insertion Loss			
Band Center	0.6 dB	0.6 dB	0.6 dB
Band Edge	1.1 dB (+/-2.69 MHz)	1.1 dB (+/-2.69 MHz)	1.1 dB (+/-2.79 MHz)
Attenuation			
+/- 3.50 MHz	≥ 1.5 dB	≥ 5 dB	≥ NA
+/- 4.50 MHz	≥ 14 dB	≥ 23 dB	≥ 19 dB
+/- 6.0 MHz	≥ 33 dB	≥ 33 dB	≥ NA
+/- 9.0 MHz	≥ 64 dB	≥ NA	≥ 53 dB
Group Delay Variation	< 150 nS	< 200 nS	< 200 nS
VSWR/RL	1.12:1/24.9 dB (+/-2.69MHz)	1.12:1/24.9 dB (+/-2.69MHz)	1.12:1/24.9 dB (+/-2.79MHz)
Ambient Temperature	0-45 C (32-113 F)		
Storage Temperature	-10 – 55 C (14 – 131 F)		
Connectors In/Out	1 5/8 EIA		
Humidity	<95% Non-Condensing		
Altitude	3048 m (10000')		
Dimensions (LxWxH)	597mm X 381 mm X 178 mm (23.25"L X 15" W X 7" H)		
Weight	20.5kg / 45 lbs		
No Sections	6		
Transmission Zeros	2		



- For indoor applications
- Temperature compensated
- For 6, 7 and 8 MHz channel bandwidths in analog TV, digital TV and mobile media applications
- DVB-T critical mask

Specifications

Model Number	UT8D7F-1.5K		
Mask	DVB-T Critical	DVB-T Critical	DVB-T2/EXT Critical
Maximum Input Power	1500 Watts		
Frequency	470-860 MHz		
Channel BW	6 MHz	7 MHz	8 MHz
Insertion Loss			
Band Center	0.8 dB	0.7 dB	0.7 dB
Band Edge	2.4 dB (+/-2.86 MHz)	2.0 dB (+/-3.40 MHz)	1.6 dB (+/-3.80 MHz) 2.0 dB (+/-3.90 MHz) Ext.
Attenuation			
+/- 3.20/3.70/X.XX MHz	≥ 15 dB	≥ 15 dB	≥ NA
+/- 4.50/5.25/4.20 MHz	≥ 28 dB	≥ 28 dB	≥ 15 dB
+/- 9.0/10.5/ 6.0 MHz	≥ 55 dB	≥ 53 dB	≥ 28 dB
+/- 12.0/12.0/12.0 MHz	≥ 60 dB	≥ 60 dB	≥ 55 dB
Group Delay Variation	<700 nS	< 700 nS	< 700 nS
VSWR/RL	1.12:1/24.9 dB (+/-2.86 MHz)	1.12:1/24.9 dB (+/-3.40 MHz)	1.12:1/24.9 dB (+/-3.90 MHz)
Ambient Temperature	0-45 C (32-113 F)		
Storage Temperature	-10 – 55 C (14 – 131 F)		
Connectors In/Out	1 5/8 EIA		
Humidity	<95% Non-Condensing		
Altitude	3048 m (10000')		
Dimensions (LxWxH)	770mm X 381 mm X 178 mm (30.25"L X 15" W X 7" H)		
Weight	26.5kg / 60 lbs		
No Sections	8		
Transmission Zeros	4		



Dielectric POWERLITE™ Series 3kW Tunable Bandpass Filter

- For indoor applications
- Temperature compensated
- For 6, 7 and 8 MHz channel bandwidths in analog TV, digital TV and mobile media applications
- DVB-T non-critical mask

Specifications

Model Number	UT6D7F-3K		
Mask	DVB-T Non-Critical	DVB-T Non-Critical	DVB-T2/EXT Non-Critical
Maximum Input Power	3000 Watts		
Frequency	470-860 MHz		
Channel BW	6 MHz	7 MHz	8 MHz
Insertion Loss			
Band Center	0.6 dB	0.5 dB	0.5 dB
Band Edge	1.1 dB (+/-2.86 MHz)	1.0 dB (+/-3.40 MHz)	1.0 dB (+/-3.80 MHz) 1.1 dB (+/-3.90 MHz) Ext.
Attenuation			
+/- 3.20/3.70/X.XX MHz	≥ 3.0 dB	≥ 3.5 dB	≥ NA
+/- 4.50/5.25/4.20 MHz	≥ 18 dB	≥ 18 dB	≥ 4.0 dB
+/- 9.0/10.5/ 6.0 MHz	≥ 40 dB	≥ 43 dB	≥ 18 dB
+/- 12.0/12.0/12.0 MHz	≥ 58 dB	≥ 55 dB	≥ 44 dB
Group Delay Variation	< 400 nS	< 350 nS	< 350 nS
VSWR/RL	1.12:1/24.9 dB (+/-2.86 MHz)	1.12:1/24.9 dB (+/-3.40 MHz)	1.12:1/24.9 dB (+/-3.90 MHz)
Ambient Temperature	0-45 C (32-113 F)		
Storage Temperature	-10 – 55 C (14 – 131 F)		
Connectors In/Out	1 5/8 EIA		
Humidity	<95% Non-Condensing		
Altitude	3048 m (10000')		
Dimensions (LxWxH)	597mm X 381 mm X 178 mm (23.25"L X 15" W X 7" H)		
Weight	20.5kg / 45 lbs		
No Sections	6		
Transmission Zeros	4		



Dielectric POWERLITE™ Series 3kW Tunable Bandpass Filter

- For indoor applications
- For 6 MHz channel bandwidths in analog TV, digital TV and mobile media applications
- ATSC full mask, ATSC stringent mask, and ISDB-T non-critical mask

Specifications

Model Number	UT6E7F-3K		
Mask	ATSC Full Mask	ATSC Stringent Mask	ISDB-T Non-Critical Mask
Maximum Input Power	3000 Watts		
Frequency	470-806 MHz		
Channel BW	6 MHz		
Insertion Loss			
Band Center	0.6 dB	0.6 dB	0.6 dB
Band Edge	1.1 dB (+/-2.69 MHz)	1.1 dB (+/-2.69 MHz)	1.1 dB (+/-2.79 MHz)
Attenuation			
+/- 3.50 MHz	≥ 1.5 dB	≥ 5 dB	≥ NA
+/- 4.50 MHz	≥ 14 dB	≥ 23 dB	≥ 19 dB
+/- 6.0 MHz	≥ 33 dB	≥ 33 dB	≥ NA
+/- 9.0 MHz	≥ 64 dB	≥ NA	≥ 53 dB
Group Delay Variation	< 150 nS	< 200 nS	< 200 nS
VSWR/RL	1.12:1/24.9 dB (+/-2.69MHz)	1.12:1/24.9 dB (+/-2.69MHz)	1.12:1/24.9 dB (+/-2.79MHz)
Ambient Temperature	0-45 C (32-113 F)		
Storage Temperature	-10 – 55 C (14 – 131 F)		
Connectors In/Out	1 5/8 EIA		
Humidity	<95% Non-Condensing		
Altitude	3048 m (10000')		
Dimensions (LxWxH)	597mm X 381 mm X 178 mm (23.25"L X 15" W X 7" H)		
Weight	20.5kg / 45 lbs		
No Sections	6		
Transmission Zeros	2		



Dielectric POWERLITE™ Series 3kW Tunable Bandpass Filter

- For indoor applications
- Temperature compensated
- For 6, 7 and 8 MHz channel bandwidths in analog TV, digital TV and mobile media applications
- DVB-T critical mask

Specifications

Model Number	UT8D7F-3K		
Mask	DVB-T Critical	DVB-T Critical	DVB-T2/EXT Critical
Maximum Input Power	3000 Watts		
Frequency	470-862 MHz		
Channel BW	6 MHz	7 MHz	8 MHz
Insertion Loss			
Band Center	0.8 dB	0.7 dB	0.7 dB
Band Edge	2.4 dB (+/-2.86 MHz)	2.0 dB (+/-3.40 MHz)	1.6 dB (+/-3.80 MHz) 2.0 dB (+/-3.90 MHz) Ext.
Attenuation			
+/- 3.20/3.70/X.XX MHz	≥ 15 dB	≥ 15 dB	≥ NA
+/- 4.50/5.25/4.20 MHz	≥ 28 dB	≥ 28 dB	≥ 15 dB
+/- 9.0/10.5/ 6.0 MHz	≥ 55 dB	≥ 53 dB	≥ 28 dB
+/- 12.0/12.0/12.0 MHz	≥ 60 dB	≥ 60 dB	≥ 55 dB
Group Delay Variation	<700 nS	< 700 nS	< 700 nS
VSWR/RL	1.12:1/24.9 dB (+/-2.86 MHz)	1.12:1/24.9 dB (+/-3.40 MHz)	1.12:1/24.9 dB (+/-3.90 MHz)
Ambient Temperature	0-45 C (32-113 F)		
Storage Temperature	-10 – 55 C (14 – 131 F)		
Connectors In/Out	1 5/8 EIA		
Humidity	<95% Non-Condensing		
Altitude	3048 m (10000')		
Dimensions (LxWxH)	770mm X 381 mm X 178 mm (30.25"L X 15" W X 7" H)		
Weight	26.5kg / 60 lbs		
No Sections	8		
Transmission Zeros	4		



Dielectric POWERLITE™ Series 7kW Tunable Bandpass Filter

Liquid Cooled

- For indoor applications
- Temperature compensated
- For 6, 7 and 8 MHz channel bandwidths in analog TV, digital TV and mobile media applications
- DVB-T non-critical mask

Specifications

Model Number	UT6D7F-7K		
Mask	DVB-T Non-Critical	DVB-T Non-Critical	DVB-T2/EXT Non-Critical
Maximum Input Power	6500 Watts		
Frequency	470-862 MHz		
Channel BW	6 MHz	7 MHz	8 MHz
Insertion Loss			
Band Center	0.6 dB	0.5 dB	0.5 dB
Band Edge	1.1 dB (+/-2.86 MHz)	1.0 dB (+/-3.40 MHz)	1.0 dB (+/-3.80 MHz) 1.1 dB (+/-3.90 MHz) Ext.
Attenuation			
+/- 3.20/3.70/X.XX MHz	≥ 3.0 dB	≥ 3.5 dB	≥ NA
+/- 4.50/5.25/4.20 MHz	≥ 18 dB	≥ 18 dB	≥ 4.0 dB
+/- 9.0/10.5/ 6.0 MHz	≥ 40 dB	≥ 43 dB	≥ 18 dB
+/- 12.0/12.0/12.0 MHz	≥ 58 dB	≥ 55 dB	≥ 44 dB
Group Delay Variation	< 400 nS	< 350 nS	< 350 nS
VSWR/RL	1.12:1/24.9 dB (+/-2.86 MHz)	1.12:1/24.9 dB (+/-3.40 MHz)	1.12:1/24.9 dB (+/-3.90 MHz)
Ambient Temperature	0-45 C (32-113 F)		
Storage Temperature	-10 – 55 C (14 – 131 F)		
Connectors In/Out	3 1/8 EIA		
Humidity	<95% Non-Condensing		
Altitude	3048 m (10000')		
Dimensions (LxWxH)	597mm X 381 mm X 178 mm (23.25"L X 15" W X 7" H)		
Weight	26.5kg / 60 lbs		
No Sections	6		
Transmission Zeros	4		



Dielectric POWERLITE™ Series 7kW Tunable Bandpass Filter

Liquid Cooled

- For indoor applications
- For 6 MHz channel bandwidths in analog TV, digital TV and mobile media applications
- ATSC full mask, ATSC stringent mask, and ISDB-T non-critical mask

Specifications

Model Number	UT6E7F-7K		
Mask	ATSC Full Mask	ATSC Stringent Mask	ISDB-T Non-Critical Mask
Maximum Input Power	6500 Watts		
Frequency	470-806 MHz		
Channel BW	6 MHz		
Insertion Loss			
Band Center	0.6 dB	0.6 dB	0.6 dB
Band Edge	1.1 dB (+/-2.69 MHz)	1.1 dB (+/-2.69 MHz)	1.1 dB (+/-2.79 MHz)
Attenuation			
+/- 3.50 MHz	≥ 1.5 dB	≥ 5 dB	≥ NA
+/- 4.50 MHz	≥ 14 dB	≥ 23 dB	≥ 19 dB
+/- 6.0 MHz	≥ 33 dB	≥ 33 dB	≥ NA
+/- 9.0 MHz	≥ 64 dB	≥ NA	≥ 53 dB
Group Delay Variation	< 150 nS	< 200 nS	< 200 nS
VSWR/RL	1.12:1/24.9 dB (+/-2.69MHz)	1.12:1/24.9 dB (+/-2.69MHz)	1.12:1/24.9 dB (+/-2.79MHz)
Ambient Temperature	0-45 C (32-113 F)		
Storage Temperature	-10 – 55 C (14 – 131 F)		
Connectors In/Out	3 1/8 EIA		
Humidity	<95% Non-Condensing		
Altitude	3048 m (10000')		
Dimensions (LxWxH)	597mm X 381 mm X 178 mm (23.25"L X 15" W X 7" H)		
Weight	26.5kg / 60 lbs		
No Sections	6		
Transmission Zeros	2		



Dielectric POWERLITE™ Series 6kW Tunable Bandpass Filter

Liquid Cooled

- For indoor applications
- Temperature compensated
- For 6, 7 and 8 MHz channel bandwidths in analog TV, digital TV and mobile media applications
- DVB-T critical mask

Specifications

Model Number	UT8D7F-6K		
Mask	DVB-T Critical	DVB-T Critical	DVB-T2/EXT Critical
Maximum Input Power	6000 Watts		
Frequency	470-862 MHz		
Channel BW	6 MHz	7 MHz	8 MHz
Insertion Loss			
Band Center	0.8 dB	0.7 dB	0.7 dB
Band Edge	2.4 dB (+/-2.86 MHz)	2.0 dB (+/-3.40 MHz)	1.6 dB (+/-3.80 MHz) 2.0 dB (+/-3.90 MHz) Ext.
Attenuation			
+/- 3.20/3.70/X.XX MHz	≥ 15 dB	≥ 15 dB	≥ NA
+/- 4.50/5.25/4.20 MHz	≥ 28 dB	≥ 28 dB	≥ 15 dB
+/- 9.0/10.5/ 6.0 MHz	≥ 55 dB	≥ 53 dB	≥ 28 dB
+/- 12.0/12.0/12.0 MHz	≥ 60 dB	≥ 60 dB	≥ 55 dB
Group Delay Variation	<700 nS	< 700 nS	< 700 nS
VSWR/RL	1.12:1/24.9 dB (+/-2.86 MHz)	1.12:1/24.9 dB (+/-3.40 MHz)	1.12:1/24.9 dB (+/-3.90 MHz)
Ambient Temperature	0-45 C (32-113 F)		
Storage Temperature	-10 – 55 C (14 – 131 F)		
Connectors In/Out	3 1/8 EIA		
Humidity	<95% Non-Condensing		
Altitude	3048 m (10000')		
Dimensions (LxWxH)	770mm X 381 mm X 178 mm (30.25"L X 15" W X 7" H)		
Weight	33 kg / 70 lbs		
No Sections	8		
Transmission Zeros	4		

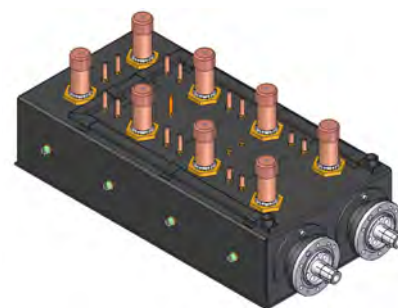

Filter Standard Masks

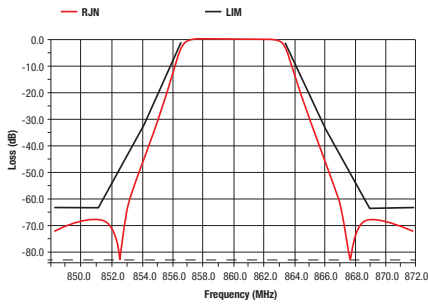

ATSC Full Mask

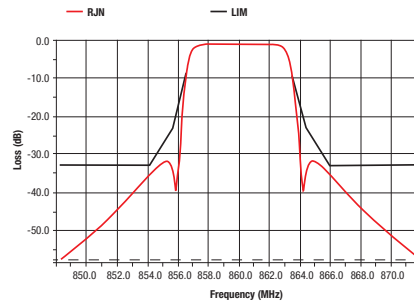

ATSC Stringent Mask

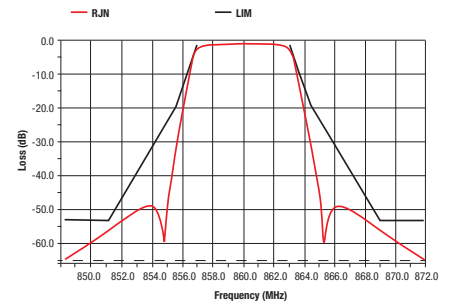

ISDB-T Non-Critical Mask

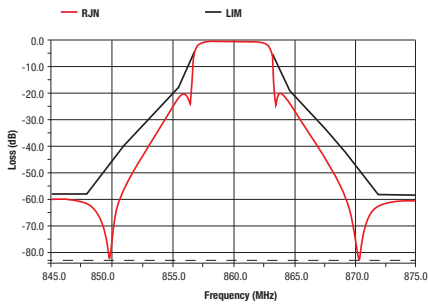

6 MHz DVB-T Non-Critical Mask

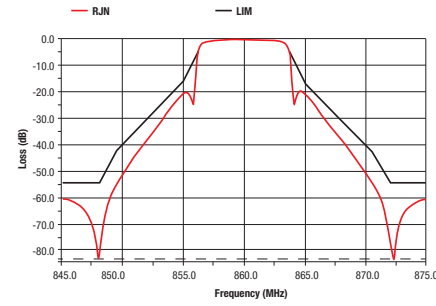

7 MHz DVB-T Non-Critical Mask

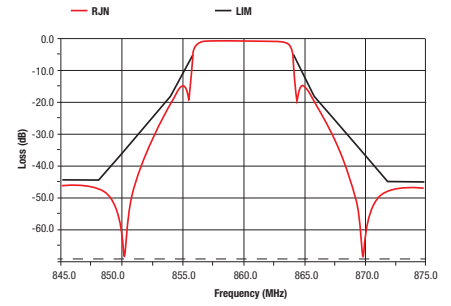

8 MHz DVB-T Non-Critical Mask

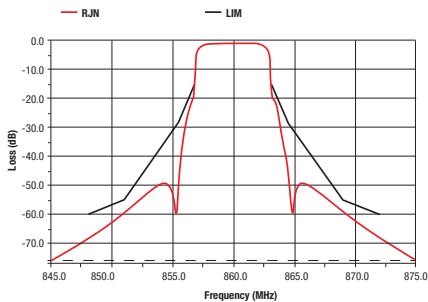

6 MHz DVB-T Critical Mask

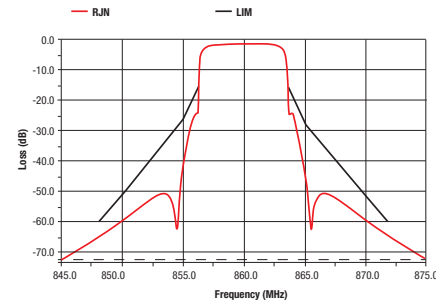

7 MHz DVB-T Critical Mask

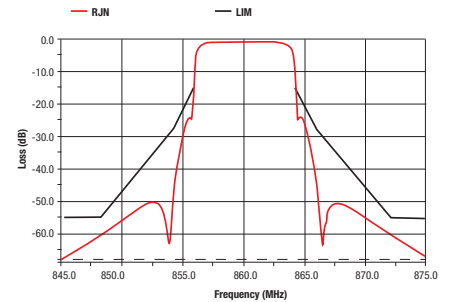

8 MHz DVB-T Critical Mask

- Are used between transmitter output and antenna system to suppress the undesirable frequency products
- Dielectric coaxial filters are tunable throughout their complete frequency range (without mechanical modifications) or within their frequency sub-bands range
- The waveguide filter is designed and built on the specified operating frequency
- The Dielectric coaxial and waveguide filters are offered for all applications in VHF & UHF for standard channel bandwidths 6, 7 and 8 MHz and for custom bandwidths requirements

VHF Bandpass Filters

Frequency	Type	Average Power Handling	Application	Response Curve	No. of Poles	Pages
54-88 MHz	R	≤ 7, 15 kW	ATV/DTV	NC	6	
54-88 MHz	R	≤ 7, 15 kW	ATV/DTV	C	8	
54-88 MHz	CIF	≤ 15, 25 kW	ATV/DTV	NC	6	
54-88 MHz	CIF	≤ 15, 25 kW	ATV/DTV	C	8	
174-230 MHz	R	≤ 4, 10 kW	ATV/DTV	NC	6, 7	
174-230 MHz	R	≤ 4, 10 kW	ATV/DTV	C	9	
174-230 MHz	CIF	≤ 10, 20 kW	ATV/DTV	NC	7	
174-230 MHz	CIF	≤ 10, 20 kW	ATV/DTV	C	9	

34
to
40

UHF Bandpass Filters

Frequency	Type	Average Power Handling	Application	Response Curve	No. of Poles	Pages
698-860 MHz	R	≤ 0.15 kW	MM	S	12	
470-860 MHz	R	≤ 0.25 kW	ATV/DTV/MM	NC, C	4, 6, 8	
698-860 MHz	R	≤ 1.0 kW	MM	S	12	
470-860 MHz	R	≤ 1.5 kW	ATV/DTV/MM	NC, C	4, 6, 8	
470-860 MHz	R	≤ 2.5 kW	ATV/DTV/MM	NC, C	4, 6, 8	
470-860 MHz	R	≤ 5, 15, 25 kW	ATV/DTV/MM	NC, C	6, 8	
470-860 MHz	CIF	≤ 7, 15, 25, 75 kW	ATV/DTV	NC, C	6, 8	

34
to
40

Notes

NC = Non-critical response (full mask, simple mask)

C = Critical response (full mask)

S = Stringent (full mask)

ATV = Analog TV

DTV = Digital TV

MM = Mobile media

R = Reflective filter

CIF = Constant impedance filter

Specifications are subject to change without notice.

Non-Critical Mask, Combine Filter

- For indoor applications
- Temperature compensated
- For 6, 7, 8 MHz channel bandwidths in analog TV, digital TV, mobile media applications

Typical Specifications for 6 MHz TV Standard

Model Number	VF6E15F
Frequency	54-88 MHz
Average Power Handling ¹	≤ 7 kW-15 kW
Type	Reflective
Response Curve	Non-critical (Full mask)
Temperature Compensated	Yes
VSWR	< 1.1
Max. Altitude ²	10,000 feet (3,050 m)

Attenuation 6 MHz ATSC

F0	< 0.2 dB
F0 +/-2.69 MHz	< 0.35 dB
F0 +/-3.00 MHz	N/A
F0 +/-3.25 MHz	N/A
F0 +/-3.50 MHz	> 0.05 dB
F0 +/-4.50 MHz	> 11.6 dB
F0 +/-6.00 MHz	> 30 dB
F0 +/-9.00 MHz	> 64 dB

Number of Poles	6
Group Delay Variation	< 150 ns over passband
Hybrids	N/A
Connectors	1-5/8" EIA/ 3-1/8" EIA
Temperature Stability	~10 kHz / °F
Blowers & Shrouds	No
Ambient Temperature	68°F (20°C) to 95°F (35°C)
Storage Temperature	32°F (0°C) to 122°F (50°C)
Ambient/Storage Humidity	0-98%, non condensing
Material	Al with Invar rods
Dimensions L x W x H	47" x 31.4" x 55" (1.2 x 0.8 x 1.4 m)
Weight	503 lbs (228 Kg)
Application	ATV/DTV

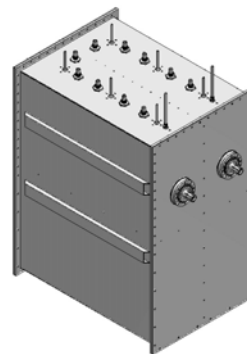
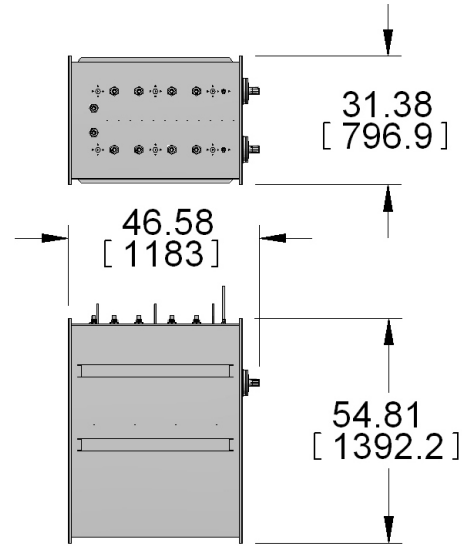

Notes

- 1) At ambient temperature 77°F (25°C), sea level, 0 PSIG
- 2) For more than 5,000 feet (1,524 m), please consult the factory.

Critical Mask, Pseudo-Elliptic Response

- For indoor applications
- Temperature compensated
- For 6, 7, 8 MHz channel bandwidths in analog TV, digital TV, mobile media applications

Typical Specifications for 6 MHz TV Standard

Model Number	VF8E11F
Frequency	54-88 MHz
Average Power Handling ¹	≤ 7 kW-20 kW
Type	Reflective
Response Curve	Critical
Temperature Compensated	Yes
VSWR	< 1.1
Max. Altitude ²	10,000 feet (3,050 m)

Attenuation 6 MHz ATSC

F0	< 0.25 dB
F0 +/-2.69 MHz	< 0.65 dB
F0 +/-3.00 MHz	< 3.65 dB
F0 +/-3.25 MHz	> 23 dB
F0 +/-3.50 MHz	N/A
F0 +/-4.50 MHz	N/A
F0 +/-6.00 MHz	N/A
F0 +/-9.00 MHz	> 64 dB

Number of Poles	8
Group Delay Variation	< 400 ns over passband
Hybrids	N/A
Connectors	1-5/8" EIA/ 3-1/8" EIA
Temperature Stability	< 50 kHz shift over temperature range
Blowers & Shrouds	No
Ambient Temperature	68°F (20°C) to 95°F (35°C)
Storage Temperature	32°F (0°C) to 122°F (50°C)
Ambient/Storage Humidity	0-98%, non condensing
Material	Al with Invar rods
Dimensions L x W x H	43" x 24" x 50" (1.0 x 0.6 x 1.3 m)
Weight	670 lbs (304 kg)
Application	ATV/DTV

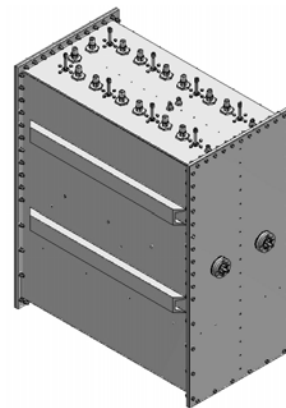
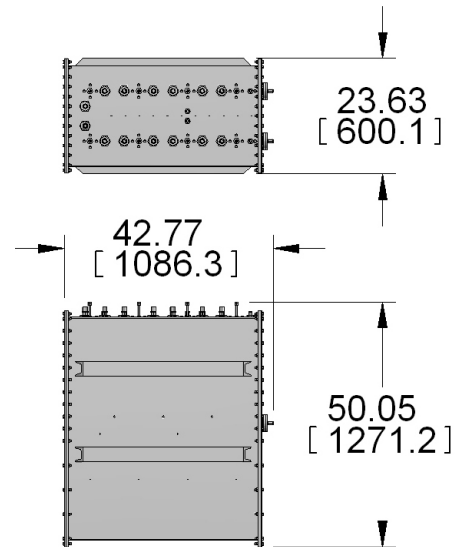

Notes

- 1) At ambient temperature 77°F (25°C), sea level, 0 PSIG
- 2) For more than 5,000 feet (1,524 m), please consult the factory.

Non-Critical Mask, Combine Filter

- For indoor applications
- For 6, 7, 8 MHz channel bandwidths in analog TV, digital TV, mobile media applications
- Temperature compensated
- CIF version used for low return loss application requirements

Typical Specifications for 6 MHz TV Standard

Model Number	CIF-VF6E15F
Frequency	54-88 MHz
Average Power Handling ¹	≤ 15 kW-25 kW
Type	CIF
Response Curve	Non-critical (Full mask)
Temperature Compensated	Yes
VSWR	< 1.06
Max. Altitude ²	10,000 feet (3,050 m)

Attenuation 6 MHz ATSC

F0	< 0.2 dB
F0 +/-2.69 MHz	< 0.35 dB
F0 +/-3.00 MHz	N/A
F0 +/-3.25 MHz	N/A
F0 +/-3.50 MHz	> 0.05 dB
F0 +/-4.50 MHz	> 11.6 dB
F0 +/-6.00 MHz	> 30 dB
F0 +/-9.00 MHz	> 64 dB

Number of Poles	6
Group Delay Variation	< 150 ns over passband
Hybrids	Coaxial
Connectors	1-5/8" EIA/ 3-1/8" EIA
Temperature Stability	~10 kHz / °F
Blowers & Shrouds	No
Ambient Temperature	68°F (20°C) to 95°F (35°C)
Storage Temperature	32°F (0°C) to 122°F (50°C)
Ambient/Storage Humidity	0-98%, non condensing
Material	Al with Invar rods
Dimensions L x W x H	64" x 60" x 70" (1.6 x 1.5 x 1.8 m)
Weight	1155 lbs (524 kg)
Application	ATV/DTV

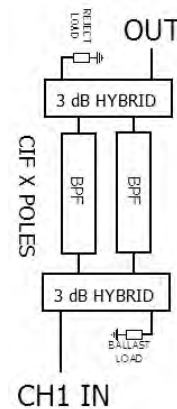
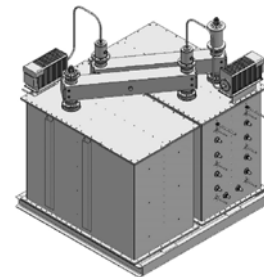
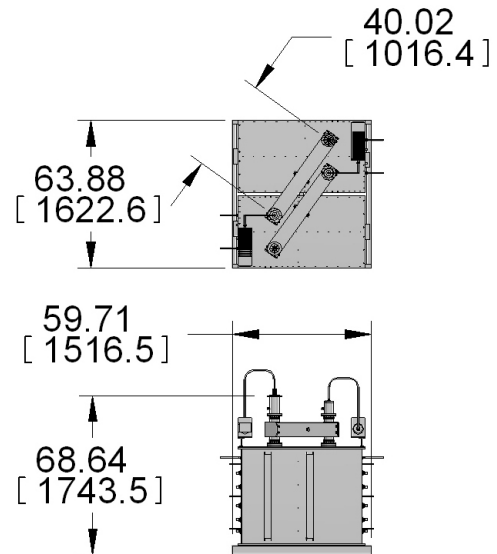

Notes

- 1) At ambient temperature 77°F (25°C), sea level, 0 PSIG
- 2) For more than 5,000 feet (1,524 m), please consult the factory.

Critical Mask, Pseudo-Elliptic Response

- For indoor applications
- For 6, 7, 8 MHz channel bandwidths in analog TV, digital TV, mobile media applications
- Temperature compensated
- CIF version used for low return loss application requirements

Typical Specifications for 6 MHz TV Standard

Model Number	CIF-VF8E11F
Frequency	54-88 MHz
Average Power Handling ¹	≤ 15 kW-25 kW
Type	CIF
Response Curve	Critical (Full mask)
Temperature Compensated	Yes
VSWR	< 1.06
Max. Altitude ²	10,000 feet (3,050 m)

Attenuation 6 MHz ATSC

F0	< 0.25 dB
F0 +/-2.69 MHz	< 0.65 dB
F0 +/-3.00 MHz	< 3.65 dB
F0 +/-3.25 MHz	> 23 dB
F0 +/-3.50 MHz	N/A
F0 +/-4.50 MHz	N/A
F0 +/-6.00 MHz	N/A
F0 +/-9.00 MHz	> 64 dB

Number of Poles	8
Group Delay Variation ³	< 400 ns over passband
Hybrids	Coaxial
Connectors	1-5/8" EIA/ 3-1/8" EIA
Temperature Stability	< 50 kHz shift over temperature range
Blowers & Shrouds	No
Ambient Temperature	68°F (20°C) to 95°F (35°C)
Storage Temperature	32°F (0°C) to 122°F (50°C)
Ambient/Storage Humidity	0-98%, non condensing
Material	Al with Invar rods
Dimensions L x W x H	85" x 48" x 68" (2.1 x 1.2 x 1.7 m)
Weight	1540 lbs (700 kg)
Application	ATV/DTV

Notes

- 1) At ambient temperature 77°F (25°C), sea level, 0 PSIG
- 2) For more than 5,000 feet (1,524 m), please consult the factory.

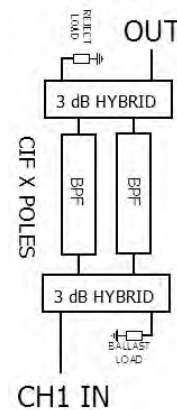
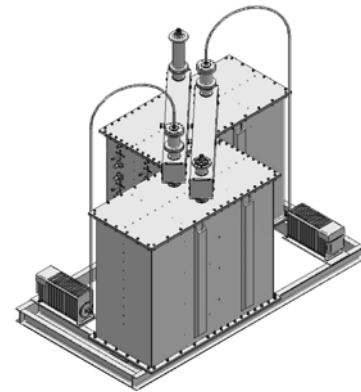
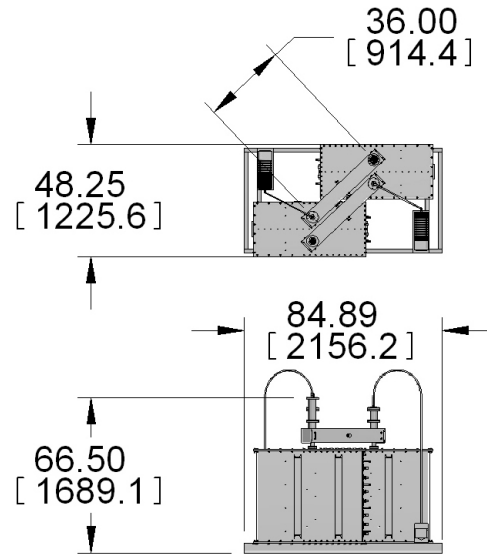

Non-Critical Mask, Interdigital Filter

- For indoor applications
- Temperature compensated
- For 6, 7, 8 MHz channel bandwidths in analog TV, digital TV, mobile media applications

Typical Specifications for 6 MHz TV Standard

Model Number	HF7T10I-10K
Frequency	174-230 MHz
Average Power Handling ¹	≤ 10 kW
Type	Reflective
Response Curve	Non-critical
Temperature Compensated	Yes
VSWR	< 1.1
Max. Altitude ²	10,000 feet (3,050 m)

Attenuation 6 MHz ATSC

F0	< 0.3 dB
F0 +/-2.69 MHz	< 0.45 dB
F0 +/-3.00 MHz	N/A
F0 +/-3.25 MHz	N/A
F0 +/-3.50 MHz	> 0.05 dB
F0 +/-4.50 MHz	> 11.6 dB
F0 +/-6.00 MHz	> 30 dB
F0 +/-9.00 MHz	> 64 dB

Number of Poles	7
Group Delay Variation	< 150 ns over passband
Hybrids	N/A
Connectors	1-5/8" EIA/ 3-1/8" EIA
Temperature Stability	~10 kHz / °F
Blowers & Shrouds	No
Ambient Temperature	68°F (20°C) to 95°F (35°C)
Storage Temperature	32°F (0°C) to 122°F (50°C)
Ambient/Storage Humidity	0-98%, non condensing
Material	Al with Invar rods
Dimensions L x W x H	86.3" x 12" x 23" (2.2 x 0.3 x 0.6 m)
Weight	300 lbs (136 kg)
Application	ATV/DTV

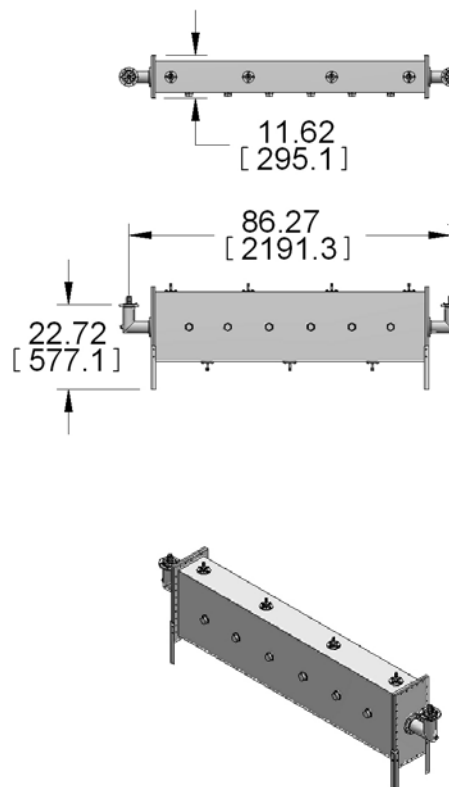

Notes

- 1) At ambient temperature 77°F (25°C), sea level, 0 PSIG
- 2) For more than 5,000 feet (1,524 m), please consult the factory.

Optional ceiling mount available. Please contact factory.

Critical Mask, Pseudo-Elliptic Response

- For indoor applications
- Temperature compensated
- For 6, 7, 8 MHz channel bandwidths in analog TV, digital TV, mobile media applications

Typical Specifications for 6 MHz TV Standard

Model Number	HF9T10I-10K
Frequency	174-230 MHz
Average Power Handling ¹	≤ 10 kW
Type	Reflective
Response Curve	Critical (Full mask)
Temperature Compensated	Yes
VSWR	< 1.1
Max. Altitude ²	10,000 feet (3,050 m)

Attenuation 6 MHz ATSC

F0	< 0.25 dB
F0 +/-2.69 MHz	< 0.65 dB
F0 +/-3.00 MHz	< 3.65 dB
F0 +/-3.25 MHz	> 18 dB
F0 +/-3.50 MHz	N/A
F0 +/-4.50 MHz	N/A
F0 +/-6.00 MHz	N/A
F0 +/-9.00 MHz	> 64 dB

Number of Poles	9
Group Delay Variation	< 450 ns over passband
Hybrids	N/A
Connectors	1-5/8" EIA/ 3-1/8" EIA
Temperature Stability	< 50 kHz shift over temperature range
Blowers & Shrouds	No
Ambient Temperature	68°F (20°C) to 95°F (35°C)
Storage Temperature	32°F (0°C) to 122°F (50°C)
Ambient/Storage Humidity	0-98%, non condensing
Material	Al with Invar rods
Dimensions L x W x H	79" x 24" x 24.3" (2.0 x 0.6 x 0.6 m)
Weight	400 lbs (182 kg)
Application	ATV/DTV

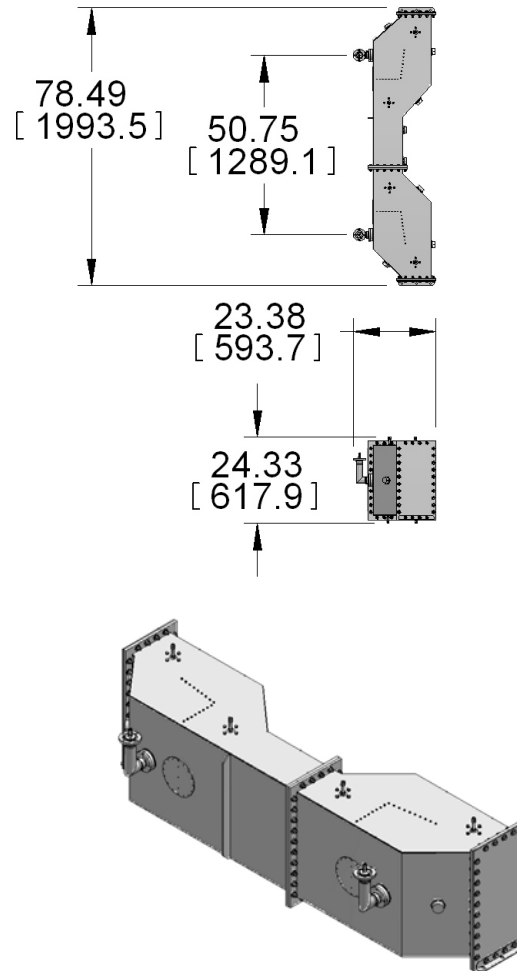

Notes

- 1) At ambient temperature 77°F (25°C), sea level, 0 PSIG
- 2) For more than 5,000 feet (1,524 m), please consult the factory.

Optional ceiling mount available. Please contact factory.

Non-Critical Mask, Interdigital Filter

- For indoor applications
- For 6, 7, 8 MHz channel bandwidths in analog TV, digital TV, mobile media applications
- Temperature compensated
- CIF version used for low return loss application requirements

Typical Specifications for 6 MHz TV Standard

Model Number	CIF-HF7T101
Frequency	174-230 MHz
Average Power Handling ¹	≤ 10 kW-20 kW
Type	CIF
Response Curve	Non-critical (Full mask)
Temperature Compensated	Yes
VSWR	< 1.06
Max. Altitude ²	10,000 feet (3,050 m)

Attenuation 6 MHz ATSC

F0	< 0.3 dB
F0 +/-2.69 MHz	< 0.45 dB
F0 +/-3.00 MHz	N/A
F0 +/-3.25 MHz	N/A
F0 +/-3.50 MHz	> 0.05 dB
F0 +/-4.50 MHz	> 11.6 dB
F0 +/-6.00 MHz	> 30 dB
F0 +/-9.00 MHz	> 64 dB

Number of Poles	7
Group Delay Variation ³	< 150 ns over passband
Hybrids	Coaxial
Connectors	1-5/8" EIA/ 3-1/8" EIA
Temperature Stability	~10 kHz / °F
Blowers & Shrouds	No
Ambient Temperature	68°F (20°C) to 95°F (35°C)
Storage Temperature	32°F (0°C) to 122°F (50°C)
Ambient/Storage Humidity	0-98%, non condensing
Material	Al with Invar rods
Dimensions L x W x H	87" x 27" x 33" (2.2 x 0.7 x 0.8 m)
Weight	700 lbs (318 kg)
Application	ATV/DTV

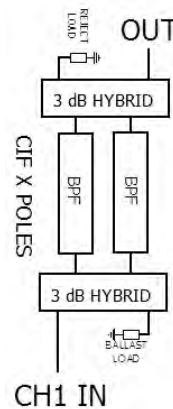
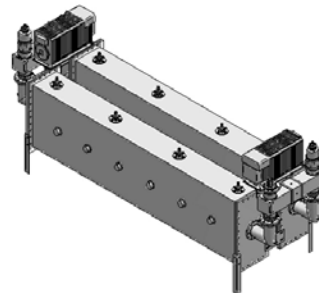
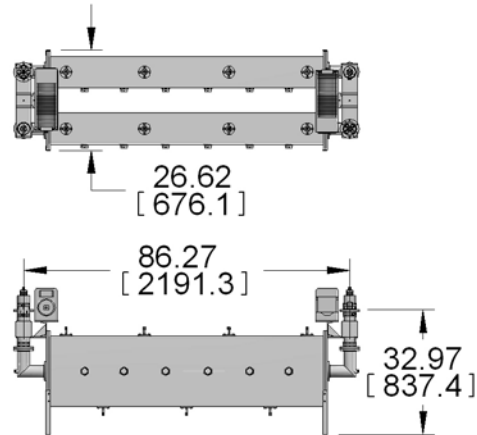

Notes

- At ambient temperature 77°F (25°C), sea level, 0 PSIG
- For more than 5,000 feet (1,524 m), please consult the factory.

Optional ceiling mount available. Please contact factory.

Critical Mask, Pseudo-Elliptic Response

- For indoor applications
- For 6, 7, 8 MHz channel bandwidths in analog TV, digital TV, mobile media applications
- Temperature compensated
- CIF version used for low return loss application requirements

Typical Specifications for 6 MHz TV Standard

Model Number	CIF-HF9T101
Frequency	174-230 MHz
Average Power Handling ¹	≤ 10 kW-20 kW
Type	CIF
Response Curve	Critical (Full mask)
Temperature Compensated	Yes
VSWR	< 1.06
Max. Altitude ²	10,000 feet (3,050 m)

Attenuation 6 MHz ATSC

F0	< 0.25 dB
F0 +/-2.69 MHz	< 0.65 dB
F0 +/-3.00 MHz	< 3.65 dB
F0 +/-3.25 MHz	> 18 dB
F0 +/-3.50 MHz	N/A
F0 +/-4.50 MHz	N/A
F0 +/-6.00 MHz	N/A
F0 +/-9.00 MHz	> 64 dB

Number of Poles	9
Group Delay Variation ³	< 450 ns over passband
Hybrids	Coaxial
Connectors	1-5/8" EIA/ 3-1/8" EIA
Temperature Stability	< 50 kHz shift over temperature range
Blowers & Shrouds	No
Ambient Temperature	68°F (20°C) to 95°F (35°C)
Storage Temperature	32°F (0°C) to 122°F (50°C)
Ambient/Storage Humidity	0-98%, non condensing
Material	Al with Invar rods
Dimensions L x W x H	94" x 49" x 38" (2.4 x 0.7 x 1.0 m)
Weight	1000 lbs (454 kg)
Application	ATV/DTV

Notes

- 1) At ambient temperature 77°F (25°C), sea level, 0 PSIG
- 2) For more than 5,000 feet (1,524 m), please consult the factory.

Optional ceiling mount available. Please contact factory.

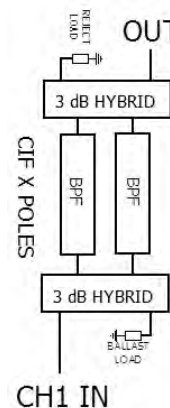
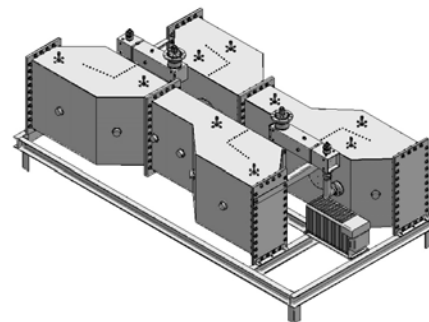
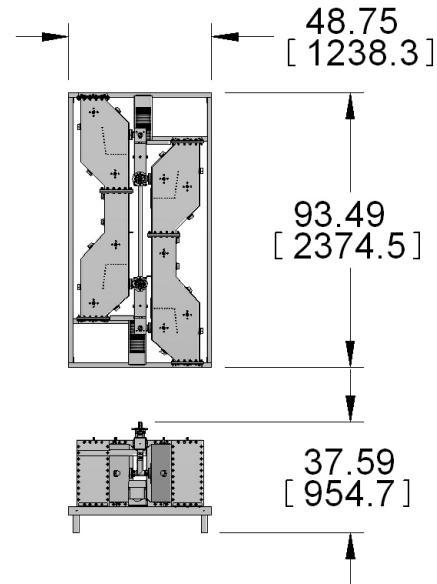

Non-Critical Mask, Chebychev Response

- For indoor applications
- Temperature compensated
- For 6, 7, 8 MHz channel bandwidths in analog TV, digital TV, mobile media applications

Typical Specifications for 6 MHz TV Standard

Model Number	UF8T18C	UF8T15C	UF8T11C
Frequency	470-494 MHz	494-680 MHz	650-860 MHz
Average Power Handling¹	7 kW - 15 kW - 25 kW	7 kW - 15 kW - 25 kW	7 kW - 15 kW - 25 kW
Type	Reflective	Reflective	Reflective
Response Curve	Non-critical (Full mask)	Non-critical (Full mask)	Non-critical (Full mask)
Temperature Compensated	Temperature tuned	Temperature tuned	Temperature tuned
VSWR	≤ 1.1	≤ 1.1	≤ 1.1
Max. Altitude²	10,000 feet (3,050 m)	10,000 feet (3,050 m)	10,000 feet (3,050 m)

Attenuation 6 MHz ATSC

F0	< 0.3 dB	< 0.3 dB	< 0.3 dB
F0 +/-2.69 MHz	< 0.3 dB	< 0.3 dB	< 0.3 dB
F0 +/-3.00 MHz	N/A	N/A	N/A
F0 +/-3.25 MHz	N/A	N/A	N/A
F0 +/-3.50 MHz	> 0.05 dB	> 0.05 dB	> 0.05 dB
F0 +/-4.50 MHz	> 11 dB	> 11 dB	> 11 dB
F0 +/-6.00 MHz	> 30.0 dB	> 30.0 dB	> 30.0 dB
F0 +/-9.00 MHz	> 55.0 dB	> 55.0 dB	> 55.0 dB

Number of Poles	8	8	8
Group Delay Variation	< 185 ns over passband	< 185 ns over passband	< 185 ns over passband
Hybrids	N/A	N/A	N/A
Connectors	3-1/8" EIA / 3-1/8" EIA / 4-1/16" FLG	3-1/8" EIA / 3-1/8" EIA / 4-1/16" FLG	3-1/8" EIA / 3-1/8" EIA / 4-1/16" FLG
Temperature Stability	~10 kHz / °F	~10 kHz / °F	~10 kHz / °F
Blowers & Shrouds	Yes, P > 10 kW	Yes, P > 10 kW	Yes, P > 10 kW
Ambient Temperature	68°F (20°C) to 95°F (35°C)	68°F (20°C) to 95°F (35°C)	68°F (20°C) to 95°F (35°C)
Storage Temperature	32°F (0°C) to 122°F (50°C)	32°F (0°C) to 122°F (50°C)	32°F (0°C) to 122°F (50°C)
Ambient/Storage Humidity	0-98%, non condensing	0-98%, non condensing	0-98%, non condensing
Material	Al	Al	Al
Dimensions³ (L x W x H)	33" x 24" x 113" (0.8 x 0.6 x 2.8 m)	33" x 24" x 113" (0.8 x 0.6 x 2.8 m)	33" x 24" x 113" (0.8 x 0.6 x 2.8 m)
Weight⁴	425 lbs (193 kg)	375 lbs (170 kg)	300 lbs (136 kg)
Application	ATV/DTV	ATV/DTV	ATV/DTV

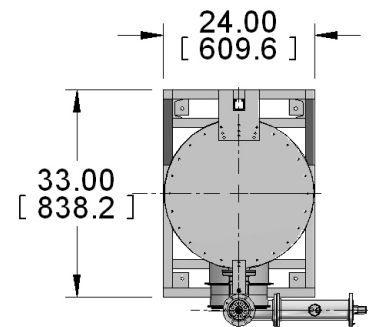
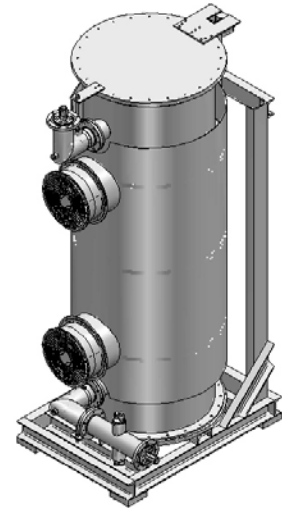

Notes

- 1) At ambient temperature 77°F (25°C), sea level, 0 PSIG
- 2) For more than 5,000 feet (1,524 m), please consult the factory.
- 3) Varies according to the channel
- 4) Estimated

Floor mounting/ceiling mounting, please contact the factory.

Non-Critical Mask, Elliptical Response

- For indoor applications
- Temperature compensated
- For 6, 7, 8 MHz channel bandwidths in analog TV, digital TV, mobile media applications

Typical Specifications for 6 MHz TV Standard

Model Number	UF6E18C	UF6E15C	UF6E11C
Frequency	470-494 MHz	494-680 MHz	650-860 MHz
Average Power Handling¹	7 kW - 15 kW - 25 kW	7 kW - 15 kW - 25 kW	7 kW - 15 kW - 25 kW
Type	Reflective	Reflective	Reflective
Response Curve	Non-critical (Full mask)	Non-critical (Full mask)	Non-critical (Full mask)
Temperature Compensated	Yes	Yes	Yes
VSWR	≤ 1.1	≤ 1.1	≤ 1.1
Max. Altitude²	10,000 feet (3,050 m)	10,000 feet (3,050 m)	10,000 feet (3,050 m)

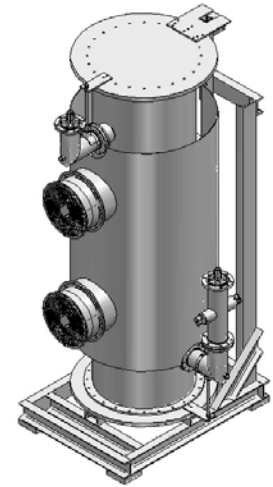

Attenuation 6 MHz ATSC

F0	< 0.25 dB	< 0.25 dB	< 0.25 dB
F0 +/-2.69 MHz	N/A	N/A	N/A
F0 +/-3.00 MHz	< 0.3 dB	< 0.3 dB	< 0.3 dB
F0 +/-3.25 MHz	N/A	N/A	N/A
F0 +/-3.50 MHz	> 0.05 dB	> 0.05 dB	> 0.05 dB
F0 +/-4.50 MHz	> 11 dB	> 11 dB	> 11 dB
F0 +/-6.00 MHz	> 30.0 dB	> 30.0 dB	> 30.0 dB
F0 +/-9.00 MHz	> 64.0 dB	> 64.0 dB	> 64.0 dB

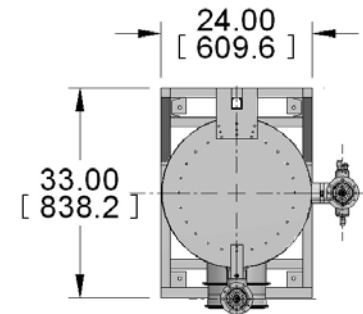

Number of Poles	6	6	6
Group Delay Variation	< 150 ns over passband	< 150 ns over passband	< 150 ns over passband
Hybrids	N/A	N/A	N/A
Connectors	3-1/8" EIA / 3-1/8" EIA / 4-1/16" FLG	3-1/8" EIA / 3-1/8" EIA / 4-1/16" FLG	3-1/8" EIA / 3-1/8" EIA / 4-1/16" FLG
Temperature Stability	< 50 kHz shift over temperature range	< 50 kHz shift over temperature range	< 50 kHz shift over temperature range
Blowers & Shrouds	Yes, P > 10 kW	Yes, P > 10 kW	Yes, P > 10 kW
Ambient Temperature	32°F (0°C) to 113°F (45°C)	32°F (0°C) to 113°F (45°C)	32°F (0°C) to 113°F (45°C)
Storage Temperature	32°F (0°C) to 122°F (50°C)	32°F (0°C) to 122°F (50°C)	32°F (0°C) to 122°F (50°C)
Ambient/Storage Humidity	0-98%, non condensing	0-98%, non condensing	0-98%, non condensing
Material	Invar	Invar	Invar
Dimensions³ L x W x H	33" x 24" x 90" (0.8 x 0.6 x 2.3 m)	33" x 24" x 90" (0.8 x 0.6 x 2.3 m)	33" x 24" x 90" (0.8 x 0.6 x 2.3 m)
Weight⁴	425 lbs (193 kg)	375 lbs (170 kg)	300 lbs (136 kg)
Application	ATV/DTV	ATV/DTV	ATV/DTV

Notes

- 1) At ambient temperature 104°F (40°C), sea level, 0 PSIG
- 2) For more than 5,000 feet (1,524 m), please consult the factory.
- 3) Varies according to the channel
- 4) Estimated

Floor mounting/ceiling mounting, please contact the factory.

Critical Mask, Elliptical Response

- Used to combine two or more channels into one antenna system
- Temperature compensated
- For 6, 7, 8 MHz custom bandwidth requirements in analog TV, digital TV, mobile media applications

Typical Specifications for 6 MHz TV Standard

Model Number	UF8E18C	UF8E15C	UF8E11C
Frequency	470-494 MHz	494-680 MHz	650-860 MHz
Average Power Handling¹	7 kW - 15 kW - 25 kW	7 kW - 15 kW - 25 kW	7 kW - 15 kW - 25 kW
Type	Reflective	Reflective	Reflective
Response Curve	Critical (Full mask)	Critical (Full mask)	Critical (Full mask)
Temperature Compensated	Yes	Yes	Yes
VSWR	≤ 1.1	≤ 1.1	≤ 1.1
Max. Altitude²	10,000 feet (3,050 m)	10,000 feet (3,050 m)	10,000 feet (3,050 m)

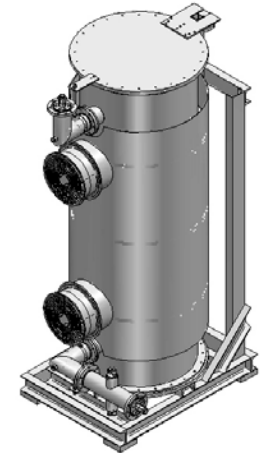

Attenuation 6 MHz ATSC

F0	< 0.3 dB	< 0.3 dB	< 0.3 dB
F0 +/-2.69 MHz	< 0.7 dB	< 0.7 dB	< 0.7 dB
F0 +/-3.00 MHz	< 2.7 dB	< 2.7 dB	< 2.7 dB
F0 +/-3.25 MHz	> 18 dB	> 18 dB	> 18 dB
F0 +/-3.50 MHz	N/A	N/A	N/A
F0 +/-4.50 MHz	N/A	N/A	N/A
F0 +/-6.00 MHz	N/A	N/A	N/A
F0 +/-9.00 MHz	> 64.0 dB	> 64.0 dB	> 64.0 dB

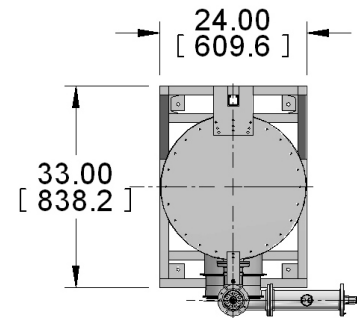

Number of Poles	8	8	8
Group Delay Variation	< 400 ns over passband	< 400 ns over passband	< 400 ns over passband
Hybrids	N/A	N/A	N/A
Connectors	3-1/8" EIA / 3-1/8" EIA / 4-1/16" FLG	3-1/8" EIA / 3-1/8" EIA / 4-1/16" FLG	3-1/8" EIA / 3-1/8" EIA / 4-1/16" FLG
Temperature Stability	< 50 kHz shift over temperature range	< 50 kHz shift over temperature range	< 50 kHz shift over temperature range
Blowers & Shrouds	Yes, P > 10 kW	Yes, P > 10 kW	Yes, P > 10 kW
Ambient Temperature	32°F (0°C) to 113°F (45°C)	32°F (0°C) to 113°F (45°C)	32°F (0°C) to 113°F (45°C)
Storage Temperature	32°F (0°C) to 122°F (50°C)	32°F (0°C) to 122°F (50°C)	32°F (0°C) to 122°F (50°C)
Ambient/Storage Humidity	0-98%, non condensing	0-98%, non condensing	0-98%, non condensing
Material	Invar	Invar	Invar
Dimensions³ L x W x H	33" x 24" x 113" (0.8 x 0.6 x 2.8 m)	33" x 24" x 113" (0.8 x 0.6 x 2.8 m)	33" x 24" x 113" (0.8 x 0.6 x 2.8 m)
Weight⁴	575 lbs (261 kg)	525 lbs (238 kg)	450 lbs (204 kg)
Application	ATV/DTV	ATV/DTV	ATV/DTV

Notes

- At ambient temperature 104°F (40°C), sea level, 0 PSIG
- For more than 5,000 feet (1,524 m), please consult the factory.
- Varies according to the channel
- Estimated

Floor mounting/ceiling mounting, please contact the factory.

Non-Critical Mask, Elliptical Response

- For indoor applications
- For 6, 7, 8 MHz channel bandwidths in analog TV, digital TV, mobile media applications
- Temperature compensated
- CIF version used for low return loss application requirements

Typical Specifications for 6 MHz TV Standard

Model Number	CIF-UF6E18C	CIF-UF6E15C	CIF-UF6E11C
Frequency	470-494 MHz	494-680 MHz	650-860 MHz
Average Power Handling¹	7-15-25-75 kW	7-15-25-75 kW	7-15-25-75 kW
Type	CIF	CIF	CIF
Response Curve	Non-critical (Full mask)	Non-critical (Full mask)	Non-critical (Full mask)
Temperature Compensated	Yes	Yes	Yes
VSWR	< 1.06	< 1.06	< 1.06
Max. Altitude²	10,000 feet (3,050 m)	10,000 feet (3,050 m)	10,000 feet (3,050 m)

Attenuation 6 MHz ATSC

F0	< 0.3 dB	< 0.3 dB	< 0.3 dB
F0 +/-2.69 MHz	< 0.3 dB	< 0.3 dB	< 0.3 dB
F0 +/-3.00 MHz	N/A	N/A	N/A
F0 +/-3.25 MHz	N/A	N/A	N/A
F0 +/-3.50 MHz	> 0.05 dB	> 0.05 dB	> 0.05 dB
F0 +/-4.50 MHz	> 11 dB	> 11 dB	> 11 dB
F0 +/-6.00 MHz	> 30.0 dB	> 30.0 dB	> 30.0 dB
F0 +/-9.00 MHz	> 64.0 dB	> 64.0 dB	> 64.0 dB

Number of Poles	6	6	6
Group Delay Variation	< 150 ns over passband	< 150 ns over passband	< 150 ns over passband
Hybrids	WR	WR	WR
Connectors	3-1/8" EIA / 3-1/8" EIA / 4-1/16" FLG / WR 1800	3-1/8" EIA / 3-1/8" EIA / 4-1/16" FLG / WR 1500	3-1/8" EIA / 3-1/8" EIA / 4-1/16" FLG / WR 1150
Temperature Stability	< 50 kHz shift over temperature range	< 50 kHz shift over temperature range	< 50 kHz shift over temperature range
Blowers & Shrouds	Yes, P > 20 kW	Yes, P > 20 kW	Yes, P > 20 kW
Ambient Temperature	32°F (0°C) to 113°F (45°C)	32°F (0°C) to 113°F (45°C)	32°F (0°C) to 113°F (45°C)
Storage Temperature	32°F (0°C) to 122°F (50°C)	32°F (0°C) to 122°F (50°C)	32°F (0°C) to 122°F (50°C)
Ambient/Storage Humidity	0-98%, non condensing	0-98%, non condensing	0-98%, non condensing
Material	Invar	Invar	Invar
Dimensions³ L x W x H	202" x 56" x 31" (5.1 x 1.4 x 0.78 m)	197" x 48" x 28" (5.0 x 1.2 x 0.7 m)	163" x 42" x 26" (4.1 x 1.0 x 0.67 m)
Weight⁴	1000 lbs (454 kg)	875 lbs (397 kg)	750 lbs (340 kg)
Application	ATV/DTV	ATV/DTV	ATV/DTV

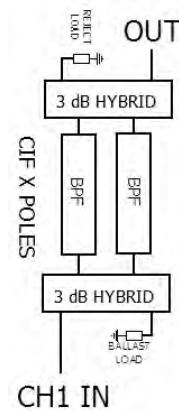
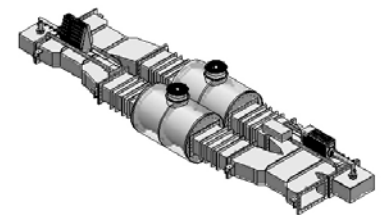
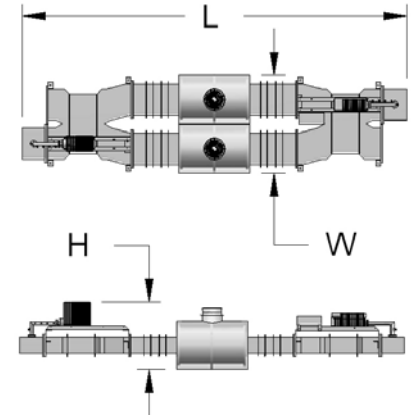

Notes

- At ambient temperature 104°F (40°C), sea level, 0 PSIG
- For more than 5,000 feet (1,524 m), please consult the factory.
- Varies according to the channel
- Estimated

Floor mounting frame available; please contact the factory.

Non-Critical Mask, Chebychev Response

- For indoor applications
- For 6, 7, 8 MHz channel bandwidths in analog TV, digital TV, mobile media applications
- Temperature compensated
- CIF version used for low return loss application requirements

Typical Specifications for 6 MHz TV Standard

Model Number	CIF-UF8T18C	CIF-UF8T15C	CIF-UF8T11C
Frequency	470-494 MHz	494-680 MHz	650-860 MHz
Average Power Handling¹	7-15-25-75 kW	7-15-25-75 kW	7-15-25-75 kW
Type	CIF	CIF	CIF
Response Curve	Non-critical (Full mask)	Non-critical (Full mask)	Non-critical (Full mask)
Temperature Compensated	Temperature tuned	Temperature tuned	Temperature tuned
VSWR	< 1.06	< 1.06	< 1.06
Max. Altitude²	10,000 feet (3,050 m)	10,000 feet (3,050 m)	10,000 feet (3,050 m)

Attenuation 6 MHz ATSC

F0	< 0.3 dB	< 0.3 dB	< 0.3 dB
F0 +/-2.69 MHz	< 0.3 dB	< 0.3 dB	< 0.3 dB
F0 +/-3.00 MHz	N/A	N/A	N/A
F0 +/-3.25 MHz	N/A	N/A	N/A
F0 +/-3.50 MHz	> 0.05 dB	> 0.05 dB	> 0.05 dB
F0 +/-4.50 MHz	> 11 dB	> 11 dB	> 11 dB
F0 +/-6.00 MHz	> 30.0 dB	> 30.0 dB	> 30.0 dB
F0 +/-9.00 MHz	> 55.0 dB	> 55.0 dB	> 55.0 dB

Number of Poles	8	8	8
Group Delay Variation	< 185 ns over passband	< 185 ns over passband	< 185 ns over passband
Hybrids	WR	WR	WR
Connectors	3-1/8" EIA/3-1/8" EIA/ FLG 4-1/16"/ WR 1800	3-1/8" EIA/3-1/8" EIA/ FLG 4-1/16"/WR 1500	3-1/8" EIA/3-1/8" EIA/ FLG 4-1/16"/WR 1150
Temperature Stability	~10 kHz / °F	~10 kHz / °F	~10 kHz / °F
Blowers & Shrouds	Yes, P > 20 kW	Yes, P > 20 kW	Yes, P > 20 kW
Ambient Temperature	68°F (20°C) to 95°F (35°C)	68°F (20°C) to 95°F (35°C)	68°F (20°C) to 95°F (35°C)
Storage Temperature	32°F (0°C) to 122°F (50°C)	32°F (0°C) to 122°F (50°C)	32°F (0°C) to 122°F (50°C)
Ambient/Storage Humidity	0-98%, non condensing	0-98%, non condensing	0-98%, non condensing
Material	Al	Al	Al
Dimensions³ L x W x H	188" x 56" x 31" (4.8 x 1.4 x 0.8 m)	174" x 48" x 28" (4.4 x 1.2 x 0.7 m)	146" x 42" x 26" (3.7 x 1.0 x 0.66 m)
Weight⁴	1000 lbs (454 kg)	875 lbs (397 kg)	750 lbs (340 kg)
Application	ATV/DTV	ATV/DTV	ATV/DTV

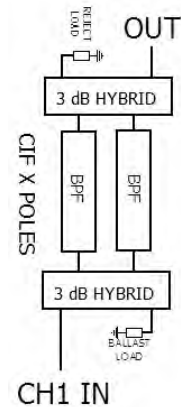
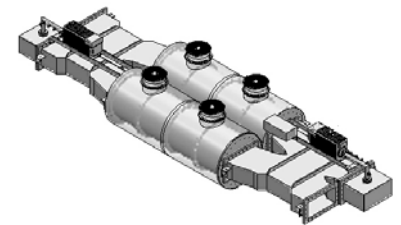
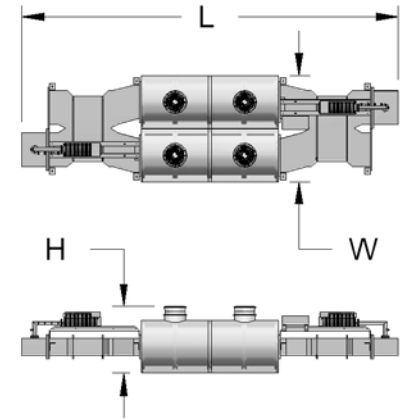

Notes

- At ambient temperature 77°F (25°C), sea level, 0 PSIG
- For more than 5,000 feet (1,524 m), please consult the factory.
- Varies according to the channel
- Estimated

Floor mounting frame available; please contact the factory.

Critical Mask, Elliptical Response

- For indoor applications
- For 6, 7, 8 MHz channel bandwidths in analog TV, digital TV, mobile media applications
- Temperature compensated
- CIF version used for low return loss application requirements

Typical Specifications for 6 MHz TV Standard

Model Number	CIF-UF8E18C	CIF-UF8E15C	CIF-UF8E11C
Frequency	470-494 MHz	494-650 MHz	650-860 MHz
Average Power Handling¹	7-15-25-75 kW	7-15-25-75 kW	7-15-25-75 kW
Type	CIF	CIF	CIF
Response Curve	Critical (Full mask)	Critical (Full mask)	Critical (Full mask)
Temperature Compensated	Yes	Yes	Yes
VSWR	< 1.06	< 1.06	< 1.06
Max. Altitude²	10,000 feet (3,050 m)	10,000 feet (3,050 m)	10,000 feet (3,050 m)

Attenuation 6 MHz ATSC

F0	< 0.3 dB	< 0.3 dB	< 0.3 dB
F0 +/-2.69 MHz	< 0.7 dB	< 0.7 dB	< 0.7 dB
F0 +/-3.00 MHz	< 2.7 dB	< 2.7 dB	< 2.7 dB
F0 +/-3.25 MHz	> 18 dB	> 18 dB	> 18 dB
F0 +/-3.50 MHz	N/A	N/A	N/A
F0 +/-4.50 MHz	N/A	N/A	N/A
F0 +/-6.00 MHz	N/A	N/A	N/A
F0 +/-9.00 MHz	> 64.0 dB	> 64.0 dB	> 64.0 dB

Number of Poles	8	8	8
Group Delay Variation	< 400 ns over passband	< 400 ns over passband	< 400 ns over passband
Hybrids	WR	WR	WR
Connectors	3-1/8" EIA/3-1/8" EIA/FLG 4-1/16"/ WR 1800	3-1/8" EIA/3-1/8" EIA/FLG 4-1/16"/ WR 1500	3-1/8" EIA/3-1/8" EIA/FLG 4-1/16"/ WR 1150
Temperature Stability	< 50 kHz shift over temperature range	< 50 kHz shift over temperature range	< 50 kHz shift over temperature range
Blowers & Shrouds	Yes, P > 20 kW	Yes, P > 20 kW	Yes, P > 20 kW
Ambient Temperature	32°F (0°C) to 113°F (45°C)	32°F (0°C) to 113°F (45°C)	32°F (0°C) to 113°F (45°C)
Storage Temperature	32°F (0°C) to 122°F (50°C)	32°F (0°C) to 122°F (50°C)	32°F (0°C) to 122°F (50°C)
Ambient/Storage Humidity	0-98%, non condensing	0-98%, non condensing	0-98%, non condensing
Material	Invar	Invar	Invar
Dimensions³ L x W x H	189" x 56" x 36" (4.8 x 1.4 x 0.9 m)	227" x 48" x 33" (5.8 x 1.2 x 0.8 m)	188" x 42" x 31" (4.8 x 1.0 x 0.8 m)
Weight⁴	1300 lbs (590 kg)	1175 lbs (533 kg)	1050 lbs (476 kg)
Application	ATV/DTV	ATV/DTV	ATV/DTV

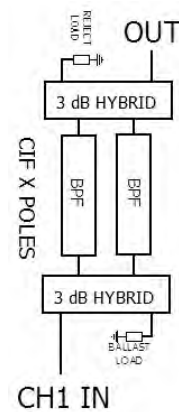
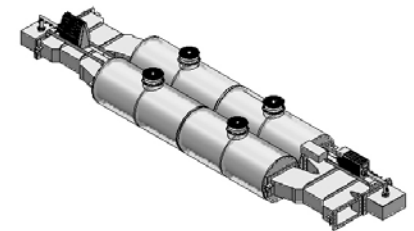
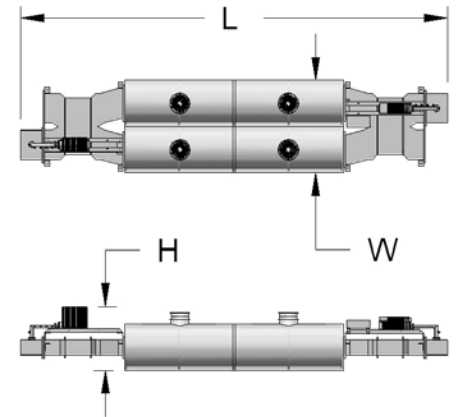

Notes

- At ambient temperature 104°F (40°C), sea level, 0 PSIG
- For more than 5,000 feet (1,524 m), please consult the factory.
- Varies according to the channel
- Estimated

Floor mounting frame available; please contact the factory.

- Are used to combine two or more channels on one antenna system
- Dielectric offers a broad range of channel combiners for dual or multiple channels in combination with switching units for customized applications
- The combiners are designed for all applications in VHF, UHF band, for standard channel bandwidths 6, 7 and 8 MHz and for custom bandwidths requirements.
- The standard types available are:
 - CIF
 - Branch (star point)
 - Manifold
- **CIF-Constant Impedance Filter balanced combiner** module is used mainly for adjacent channel situations and can be easily extended or be combined with any other combiners like: manifold, branch, or directional waveguide filter combiners.

A CIF combiner module consists of a balanced pair of band pass filters, two 3 dB couplers and a balancing load. The transmitter signal is fed into the NB (narrow band) input, the channels previously combined or another single channel is fed to the WB (wide band) input and the combined output is directed to the antenna system or to the next wide band input of the next module (a cascade multi-channel combiner configuration).
- **Branch or star point combiners** use a band pass filter per transmitter/channel to be combined, that are connected to a common output. It is the most economical solution for two channels wide frequency spaced. They are available in a coaxial or waveguide version depending on the power handling requirement.
- **Manifold combiner** consists of a band pass filter for each the transmitter/channel, a TEE junction for each input frequency and a short circuit stub. They are built in coaxial or waveguide versions. It is an economical solution for multichannels combining with a minimum of two channels spacing in between.

VHF Combiners

Type	Frequency	Total Average Power	Mask Filters	Pages
CIF	54-88 MHz	≤ 25 kW	ATV/DTV	50-51
CIF	174-230 MHz	≤ 7 kW, 25 kW	ATV/DTV	52-53

UHF Combiners

Type	Frequency	Average Power Handling	Application	Pages
CIF	470-860 MHz	≤ 0.4 kW, 0.5 kW	ATV/DTV	54 to 55
CIF	470-860 MHz	≤ 3.0 kW	ATV/DTV	
CIF	470-860 MHz	≤ 5.0 kW	ATV/DTV	
CIF	470-860 MHz	≤ 15 kW to 75 kW	ATV/DTV	

Branch	470-860 MHz	≤ 15 kW, 25 kW	ATV/DTV/MM	56
--------	-------------	----------------	------------	----

Manifold	470-860 MHz	≤ 110 kW	ATV/DTV	57
----------	-------------	----------	---------	----

Notes

DTV = Digital TV (ATSC/DVB/ISDB-T)

ATV = Analog TV (NTSC, PAL, SECAM)

MM = Mobile media

Specifications are subject to change without notice.

With Filters (CIF)

- Suitable for analog and digital TV or mobile media applications
- Temperature compensated
- Low VSWR
- Dielectric is offering the CIF channel combiner with filters, tuned for mask filter requirements too

Typical Specifications for 6 MHz TV Standard

Model Number	CLV2CN62
Total Average Power ¹	25 kW
Frequency	54-88 MHz
Channel Spacing	≥ 1

Narrow Band Input

Average Power Handling ¹	20 kW
Response Curve	Non-critical (Full mask)
Temperature Compensated	Temperature tuned

Insertion Loss 6 MHz ATSC

F0	< 0.2 dB
F0 +/-2.69 MHz	< 0.35 dB
F0 +/-3.50 MHz	> 0.05 dB
F0 +/-4.50 MHz	> 11.6 dB
F0 +/-6.00 MHz	> 30 dB
F0 +/-9.00 MHz	> 64 dB
Group Delay Variation ²	< 150 ns over passband
Connector	1-5/8" EIA/ 3-1/8" EIA

Wide Band Input

Average Power Handling ^{1,3}	5 kW
Insertion Loss	≤ 0.1 dB
Group Delay Variation ²	< 10 ns over passband
Connector	1-5/8" EIA/ 3-1/8" EIA

Output Connector	1-5/8" EIA/ 3-1/8" EIA
------------------	------------------------

Isolation Between Inputs

NB to WB	≥ 35 dB
WB to NB	≥ 50 dB

VSWR	< 1.06
Material	Al
Hybrids Type	Coaxial
Number of Poles	6
Temperature Stability	~10 kHz / °F
Blowers & Shrouds	No
Ambient Temperature	68°F (20°C) to 95°F (35°C)
Storage Temperature	32°F (0°C) to 122°F (50°C)
Ambient/Storage Humidity	0-98%, non condensing
Dimensions (L x W x H)	64" x 60" x 70" (1.6 x 1.5 x 1.8 m)
Weight	1155 lbs (524 kg)
Max. Altitude ⁴	10,000 feet (3,050 m)
Application	ATV/DTV

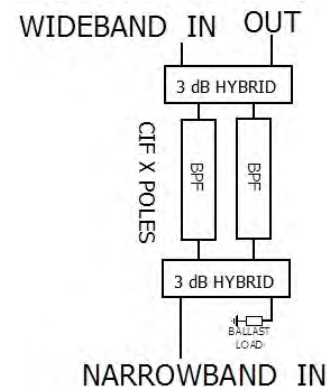
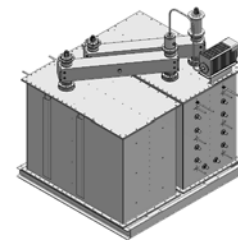
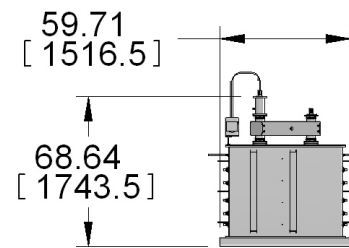
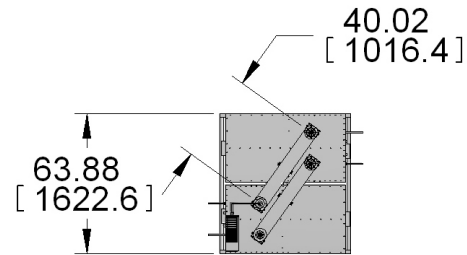

Notes

- 1) Measured at 77°F (25°C), sea level, 0 PSIG
 - 2) Group delay variation over the pass band
 - 3) By reducing the average input at NB input, half of the power reduced can be added to the WB input
 - 4) For more than 5,000 feet (1,524 m), please contact the factory.
- Floor mounting frame available; please contact the factory.

With Filters (CIF)

- Suitable for analog and digital TV or mobile media applications
- Temperature compensated

- Low VSWR
- Dielectric is offering the CIF channel combiner with filters, tuned for mask filter requirements too

Typical Specifications for 6 MHz TV Standard

Model Number	CLV2CC82
Total Average Power ¹	25 kW
Frequency	54-88 MHz
Channel Spacing	≥ 0

Narrow Band Input

Average Power Handling ¹	15 kW
Response Curve	Critical (Full mask)
Temperature Compensated	Yes

Insertion Loss 6 MHz ATSC

F0	< 0.25 dB
F0 +/-2.69 MHz	< 0.65 dB
F0 +/-3.00 MHz	< 3.65 dB
F0 +/-3.25 MHz	> 23 dB
F0 +/-9.00 MHz	> 64 dB
Group Delay Variation ²	< 400 ns over passband
Connector	1-5/8" EIA/ 3-1/8" EIA

Wide Band Input

Average Power Handling ^{1,3}	5 kW
Insertion Loss	≤ 0.1 dB
Group Delay Variation ²	< 300 ns over passband
Connector	1-5/8" EIA/ 3-1/8" EIA

Output Connector	1-5/8" EIA/ 3-1/8" EIA
------------------	------------------------

Isolation Between Inputs

NB to WB	≥ 35 dB
WB to NB	≥ 50 dB

VSWR	< 1.06
Material	Al with Invar rods
Hybrids Type	Coaxial
Number of Poles	8
Temperature Stability	< 50 kHz shift over temperature range
Blowers & Shrouds	No
Ambient Temperature	68°F (20°C) to 95°F (35°C)
Storage Temperature	32°F (0°C) to 122°F (50°C)
Ambient/Storage Humidity	0-98%, non condensing
Dimensions (L x W x H)	85" x 48" x 68" (2.1 x 1.2 x 1.7 m)
Weight	1540 lbs (700 kg)
Max. Altitude ⁴	10,000 feet (3,050 m)
Application	ATV/DTV

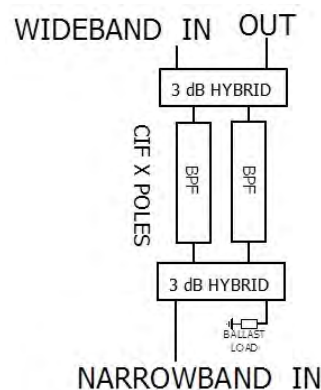
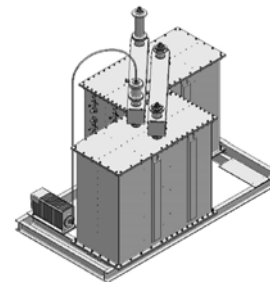
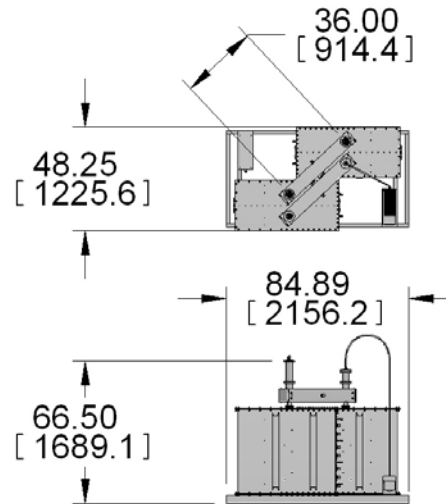

Notes

- 1) Measured at 77°F (25°C), sea level, 0 PSIG
 - 2) Group delay variation over the pass band
 - 3) By reducing the average input at NB input, half of the power reduced can be added to the WB input
 - 4) For more than 5,000 feet (1,524 m), please contact the factory.
- Floor mounting frame available; please contact the factory.

With Filters (CIF)

- Suitable for analog and digital TV or mobile media applications
- Temperature compensated
- Low VSWR
- Dielectric is offering the CIF channel combiner with filters, tuned for mask filter requirements too

Typical Specifications for 6 MHz TV Standard

Model Number	CHV2CN72
Total Average Power ¹	25 kW
Frequency	174-230 MHz
Channel Spacing	≥ 1

Narrow Band Input

Average Power Handling ¹	15 kW
Response Curve	Non-critical (Full mask)
Temperature Compensated	Temperature tuned

Insertion Loss 6 MHz ATSC

F0	< 0.3 dB
F0 +/-2.69 MHz	< 0.45 dB
F0 +/-3.50 MHz	> 0.05 dB
F0 +/-4.50 MHz	> 11.6 dB
F0 +/-6.00 MHz	> 30 dB
F0 +/-9.00 MHz	> 64 dB
Group Delay Variation ²	< 150 ns over passband
Connector	1-5/8" EIA/ 3-1/8" EIA

Wide Band Input

Average Power Handling ^{1,3}	10 kW
Insertion Loss	≤ 0.1 dB
Group Delay Variation ²	< 10 ns over passband
Connector	1-5/8" EIA/ 3-1/8" EIA

Output Connector

3-1/8" EIA

Isolation Between Inputs

NB to WB	≥ 35 dB
WB to NB	≥ 50 dB

VSWR	< 1.06
Material	Al
Hybrids Type	Coaxial
Number of Poles	7
Temperature Stability	~10 kHz / °F
Blowers & Shrouds	No
Ambient Temperature	68°F (20°C) to 95°F (35°C)
Storage Temperature	32°F (0°C) to 122°F (50°C)
Ambient/Storage Humidity	0-98%, non condensing
Dimensions (L x W x H)	87" x 27" x 33" (2.2 x 0.7 x 0.8 m)
Weight	700 lbs (318 kg)
Max. Altitude ⁴	10,000 feet (3,050 m)
Application	ATV/DTV

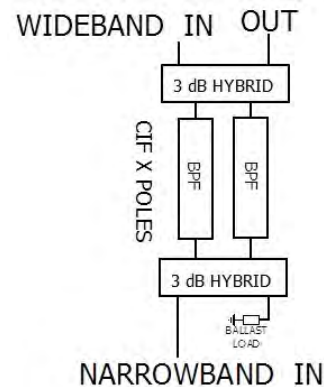
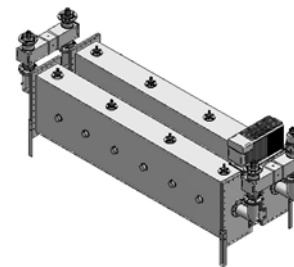
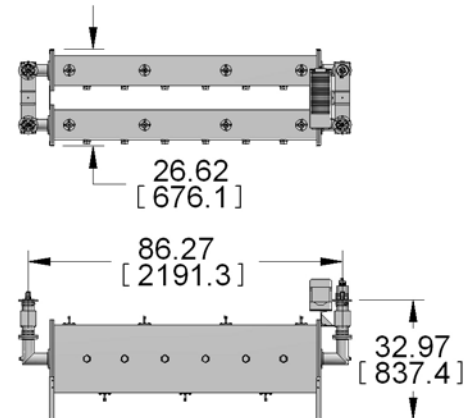

Notes

- 1) Measured at 77°F (25°C), sea level, 0 PSIG
 - 2) Group delay variation over the pass band
 - 3) By reducing the average input at NB input, half of the power reduced can be added to the WB input
 - 4) For more than 5,000 feet (1,524 m), please contact the factory.
- Floor mounting frame available; please contact the factory.

With Filters (CIF)

- Suitable for analog and digital TV or mobile media applications
- Temperature compensated
- Low VSWR
- Dielectric is offering the CIF channel combiner with filters, tuned for mask filter requirements too

Typical Specifications for 6 MHz TV Standard

Model Number	CHV2CC92
Total Average Power ¹	16 kW
Frequency	174-230 MHz
Channel Spacing	≥ 0

Narrow Band Input

Average Power Handling ¹	15 kW
Response Curve	Critical (Full mask)
Temperature Compensated	Yes

Insertion Loss 6 MHz ATSC

F0	< 0.25 dB
F0 +/-2.69 MHz	< 0.65 dB
F0 +/-3.00 MHz	< 3.65 dB
F0 +/-3.25 MHz	> 18 dB
F0 +/-9.00 MHz	> 64 dB
Group Delay Variation ²	< 450 ns over passband
Connector	1-5/8" EIA / 3-1/8" EIA

Wide Band Input

Average Power Handling ^{1,3}	10 kW
Insertion Loss	≤ 0.1 dB
Group Delay Variation ²	< 350 ns over passband
Connector	1-5/8" EIA / 3-1/8" EIA

Output Connector	3-1/8" EIA
------------------	------------

Isolation Between Inputs

NB to WB	≥ 35 dB
WB to NB	≥ 50 dB

VSWR	< 1.06
Material	Al with Invar rods
Hybrids Type	Coaxial
Number of Poles	9
Temperature Stability	< 50 kHz shift over temperature range
Blowers & Shrouds	No
Ambient Temperature	68°F (20°C) to 95°F (35°C)
Storage Temperature	32°F (0°C) to 122°F (50°C)
Ambient/Storage Humidity	0-98%, non condensing
Dimensions (L x W x H)	94" x 49" x 38" (2.4 x 0.7 x 1.0 m)
Weight	1000 lbs (454 kg)
Max. Altitude ⁴	10,000 feet (3,050 m)
Application	ATV/DTV

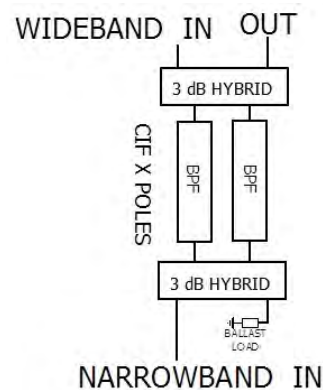
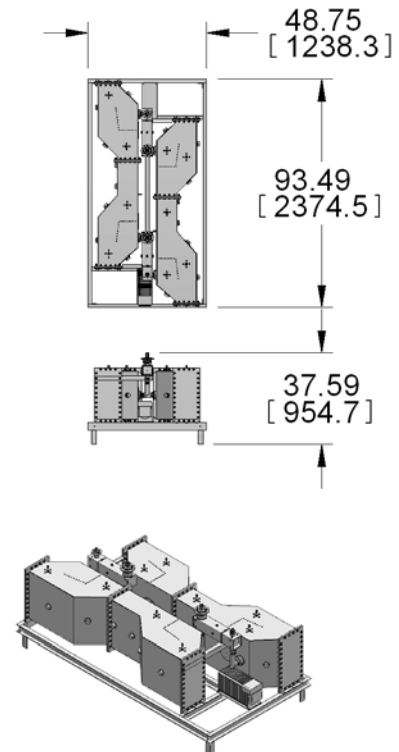

Notes

- 1) Measured at 77°F (25°C), sea level, 0 PSIG
 - 2) Group delay variation over the pass band
 - 3) By reducing the average input at NB input, half of the power reduced can be added to the WB input
 - 4) For more than 5,000 feet (1,524 m), please contact the factory.
- Floor mounting frame available; please contact the factory.

With Filters (CIF), Elliptical Response

- Suitable for analog and digital TV or mobile media applications
- Temperature compensated
- Low VSWR
- Dielectric is offering the CIF channel combiner with filters, tuned for mask filter requirements too

Typical Specifications for 6 MHz TV Standard

Model Number	CU182CN63	CU152CN63	CU112CN63
Total Average Power ¹	15 kW -30 kW -75 kW	15 kW -305 kW -75 kW	15 kW -30 kW -75 kW
Frequency	470-494 MHz	494-680 MHz	650-860 MHz
Channel Spacing	≥ 1	≥ 1	≥ 1

Narrow Band Input

Average Power Handling ¹	10 kW-20 kW-55 kW	10 kW-20 kW-55 kW	10 kW-20 kW-55 kW
Response Curve	Non-critical	Non-critical	Non-critical
Temperature Compensated	Yes	Yes	Yes

Insertion Loss 6 MHz ATSC

F0	< 0.3 dB	< 0.3 dB	< 0.3 dB
F0 +/-2.69 MHz	< 0.3 dB	< 0.3 dB	< 0.3 dB
F0 +/-3.50 MHz	> 0.05 dB	> 0.05 dB	> 0.05 dB
F0 +/-4.50 MHz	> 10.3 dB	> 10.3 dB	> 10.3 dB
F0 +/-6.00 MHz	> 30.0 dB	> 30.0 dB	> 30.0 dB
F0 +/-9.00 MHz	> 64.0 dB	> 64.0 dB	> 64.0 dB
Group Delay Variation ²	< 150 ns over passband	< 150 ns over passband	< 150 ns over passband
Connector	3-1/8" EIA/FLG 4-1/16"/WR 1800	3-1/8" EIA/FLG 4-1/16"/WR 1500	3-1/8" EIA/FLG 4-1/16"/WR 1150

Wide Band Input

Average Power Handling ^{1,3}	5 kW-10 kW, 20 kW	5 kW-10 kW, 20 kW	5 kW-10 kW, 20 kW
Insertion Loss	≤ 0.1 dB	≤ 0.1 dB	≤ 0.1 dB
Group Delay Variation ²	< 10 ns over passband	< 10 ns over passband	< 10 ns over passband
Connector	3-1/8" EIA/ WR 1800	3-1/8" EIA/ WR 1500	3-1/8" EIA/ WR 1150
Output Connector	3-1/8" EIA/FLG 4-1/16"/WR 1800	3-1/8" EIA/FLG 4-1/16"/WR 1500	3-1/8" EIA/FLG 4-1/16"/WR 1150

Isolation Between Inputs

NB to WB	≥ 35 dB	≥ 35 dB	≥ 35 dB
WB to NB	≥ 50 dB	≥ 50 dB	≥ 50 dB
VSWR	< 1.06	< 1.06	< 1.06
Material	Invar	Invar	Invar
Hybrids Type	WR	WR	WR
Number of Poles	6	6	6
Temperature Stability	< 50 kHz shift over temperature range	< 50 kHz shift over temperature range	< 50 kHz shift over temperature range
Blowers & Shrouds	Yes. P > 20 kW	Yes. P > 20 kW	Yes. P > 20 kW
Ambient Temperature	32°F (0°C) to 113°F (45°C)	32°F (0°C) to 113°F (45°C)	32°F (0°C) to 113°F (45°C)
Storage Temperature	32°F (0°C) to 122°F (50°C)	32°F (0°C) to 122°F (50°C)	32°F (0°C) to 122°F (50°C)
Ambient/Storage Humidity	0-98%, non condensing	0-98%, non condensing	0-98%, non condensing
Dimensions (L x W x H)	202" x 56" x 31" (5.1 x 1.4 x 0.78 m)	197" x 48" x 28" (5.0 x 1.2 x 0.7 m)	163" x 42" x 26" (4.1 x 1.0 x 0.67 m)
Weight	1000 lbs (454 kg)	875 lbs (397 kg)	750 lbs (340 kg)
Max. Altitude ⁴	10,000 feet (3,050 m)	10,000 feet (3,050 m)	10,000 feet (3,050 m)
Application	ATV/DTV	ATV/DTV	ATV/DTV

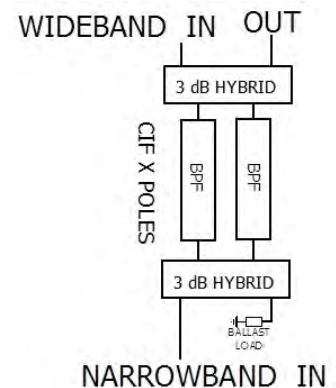
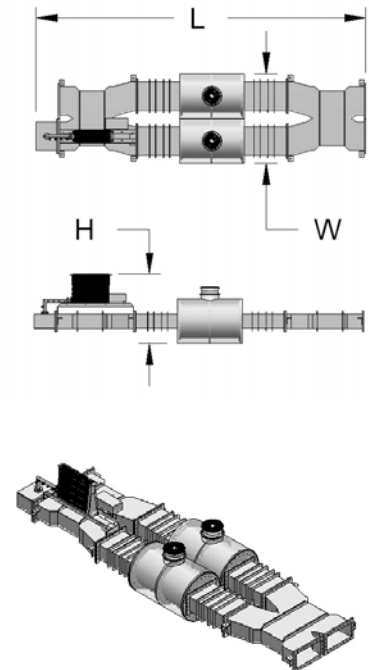

Notes

- 1) At ambient temperature 104°F (40°C), sea level, 0 PSIG
 - 2) Group delay variation over the pass band
 - 3) By reducing the average input at NB input, half of the power reduced can be added to the WB input
 - 4) For more than 5,000 feet (1,524 m), please contact the factory.
- Floor mounting frame available; please contact the factory.

With Filters (CIF), Elliptical Response

- Suitable for analog and digital TV or mobile media applications
- Temperature compensated
- Low VSWR
- Dielectric is offering the CIF channel combiner with filters, tuned for mask filter requirements too

Typical Specifications for 6 MHz TV Standard

Model Number	CU182CC83	CU152CC83	CU112CC83
Total Average Power ¹	15 kW-30 kW-75 kW	15 kW-30 kW-75 kW	15 kW-30 kW-75 kW
Frequency	470-494 MHz	494-680 MHz	650-860 MHz
Channel Spacing	≥ 0	≥ 0	≥ 0

Narrow Band Input

Average Power Handling ¹	10 kW-20 kW-55 kW	10 kW-20 kW-55 kW	10 kW-20 kW-55 kW
Response Curve	Critical (Full mask)	Critical (Full mask)	Critical (Full mask)
Temperature Compensated	Yes	Yes	Yes

Insertion Loss 6 MHz ATSC

F0	< 0.3 dB	< 0.3 dB	< 0.3 dB
F0 +/-2.69 MHz	< 0.7 dB	< 0.7 dB	< 0.7 dB
F0 +/-3.00 MHz	< 2.7 dB	< 2.7 dB	< 2.7 dB
F0 +/-3.25 MHz	> 18 dB	> 18 dB	> 18 dB
F0 +/-9.00 MHz	> 64 dB	> 64 dB	> 64 dB
Group Delay Variation ²	< 400 ns over passband	< 400 ns over passband	< 400 ns over passband
Connector	3-1/8" EIA/FLG 4-1/16"/WR 1800	3-1/8" EIA/FLG 4-1/16"/WR 1500	3-1/8" EIA/FLG 4-1/16"/WR 1150

Wide Band Input

Average Power Handling ^{1,3}	5 kW-10 kW-20 kW	5 kW-10 kW-20 kW	5 kW-10 kW-20 kW
Insertion Loss	≤ 0.1 dB	≤ 0.1 dB	≤ 0.1 dB
Group Delay Variation ²	< 400 ns over passband	< 400 ns over passband	< 400 ns over passband
Connector	3-1/8" EIA/ WR 1800	3-1/8" EIA/ WR 1500	3-1/8" EIA/ WR 1150
Output Connector	3-1/8" EIA/FLG 4-1/16"/WR 1800	3-1/8" EIA/FLG 4-1/16"/WR 1500	3-1/8" EIA/FLG 4-1/16"/WR 1150

Isolation Between Inputs

NB to WB	≥ 35 dB	≥ 35 dB	≥ 35 dB
WB to NB	≥ 50 dB	≥ 50 dB	≥ 50 dB
VSWR	< 1.06	< 1.06	< 1.06
Material	Invar	Invar	Invar
Hybrids Type	WR	WR	WR
Number of Poles	8	8	8
Temperature Stability	< 50 kHz shift over temperature range	< 50 kHz shift over temperature range	< 50 kHz shift over temperature range
Blowers & Shrouds	Yes. P > 20 kW	Yes. P > 20 kW	Yes. P > 20 kW
Ambient Temperature	32°F (0°C) to 113°F (45°C)	32°F (0°C) to 113°F (45°C)	32°F (0°C) to 113°F (45°C)
Storage Temperature	32°F (0°C) to 122°F (50°C)	32°F (0°C) to 122°F (50°C)	32°F (0°C) to 122°F (50°C)
Ambient/Storage Humidity	0-98%, non condensing	0-98%, non condensing	0-98%, non condensing
Dimensions (L x W x H)	189" x 56" x 36" (4.8 x 1.4 x 0.9 m)	227" x 48" x 33" (5.8 x 1.2 x 0.8 m)	188" x 42" x 31" (4.8 x 1.0 x 0.8 m)
Weight	1300 lbs (590 kg)	1175 lbs (533 kg)	1050 lbs (476 kg)
Max. Altitude ⁴	10,000 feet (3,050 m)	10,000 feet (3,050 m)	10,000 feet (3,050 m)
Application	ATV/DTV	ATV/DTV	ATV/DTV

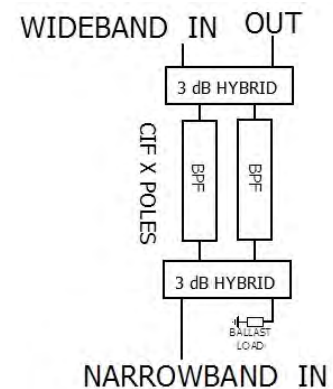
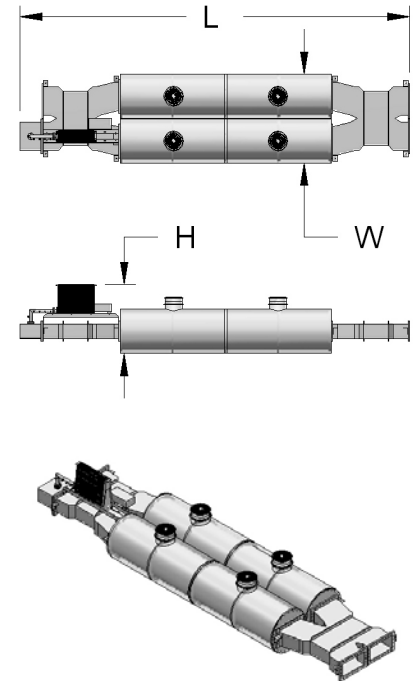

Notes

- 1) At ambient temperature 104°F (40°C), sea level, 0 PSIG
- 2) Group delay variation over the pass band
- 3) By reducing the average input at NB input, half of the power reduced can be added to the WB input
- 4) For more than 5,000 feet (1,524 m), please contact the factory.

Floor mounting frame available; please contact the factory.

Coaxial Branch

- Suitable for analog and digital TV or mobile media applications
- Temperature compensated
- Low VSWR

Typical Specifications for 6 MHz TV Standard

Model Number	CU2B062
Total Average Power ¹	15 kW-25 kW
Frequency	470-860 MHz
Combiner Type	Branch

Channel Spacing

Minimum	2
Maximum	20

Channel 1, 2 Input

Average Power Handling	7.5 kW-12.5 kW
Response Curve	No
Insertion Loss	< 0.25 dB
Temperature Compensated	Temperature tuned
Group Delay Variation	< 20 ns over passband
Connector	3-1/8" EIA

Output Connector ³	3-1/8" EIA/4-1/16" FLG
-------------------------------	------------------------

Isolation Between Inputs	≥ 40 dB
VSWR	< 1.06
Material	Al
Connection Type	Coaxial
Temperature Stability	< 50 kHz shift over temperature range
Blowers & Shrouds	No
Ambient Temperature	32°F (0°C) to 114°F (45°C)
Storage Temperature	32°F (0°C) to 122°F (50°C)
Ambient/Storage Humidity	0-98% non condensing
Dimensions	Contact the factory
Weight	Contact the factory
Max. Altitude ²	10,000 feet (3,050 m)
Application	ATV/DTV

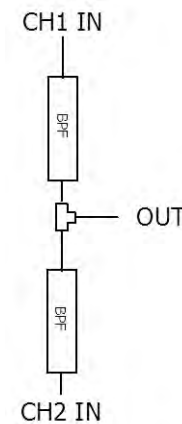
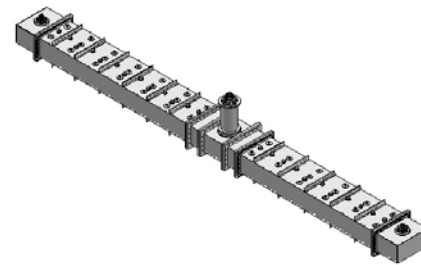
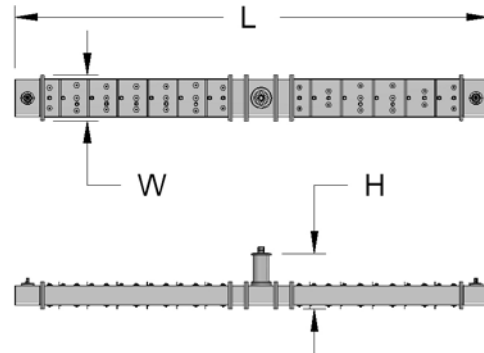

Notes

- 1) Measured at 104°F (40°C), sea level, 0 PSIG
- 2) For more than 5,000 feet (1,524 m), please contact the factory
- 3) The total power output is max 200 kW and is limited by coaxial in/out size

Floor mounting frame available; please contact the factory.

- Suitable for analog and digital TV or mobile media applications
- Temperature compensated
- Low VSWR

Typical Specifications for 6 MHz TV Standard

Model Number	CU2M0631
Total Average Power¹	110 kW
Frequency	470-860 MHz
Combiner Type	Manifold
Channel Spacing	
Minimum	2
Maximum	30
Channel 1, 2 Input	
Average Power Handling	55 kW
Response Curve	No
Insertion Loss	< 0,25 dB
Temperature Compensated	Temperature tuned
Group Delay Variation	< 20 ns over passband
Connector	WR
Output Connector	
	WR
Isolation Between Inputs	≥ 40 dB
VSWR	< 1.06
Material	Al
Connection Type	WR 1800/1500/1150
Temperature Stability	< 50 kHz shift over temperature range
Blowers & Shrouds	> 50 kW
Ambient Temperature	32°F (0°C) to 114°F (45°C)
Storage Temperature	32°F (0°C) to 122°F (50°C)
Ambient/Storage Humidity	0-98% non condensing
Dimensions	Contact the factory
Weight	Contact the factory
Max. Altitude²	10,000 feet (3,050 m)
Application	ATV/DTV

Notes

- 1) Measured at 104°F (40°C), sea level, 0 PSIG
 - 2) For more than 5,000 feet (1,524 m), please contact the factory
- Floor mounting frame available; please contact the factory.

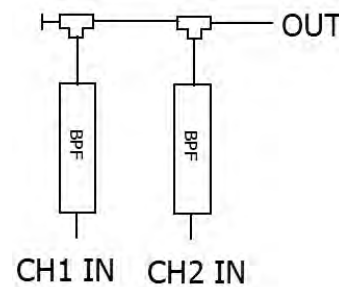
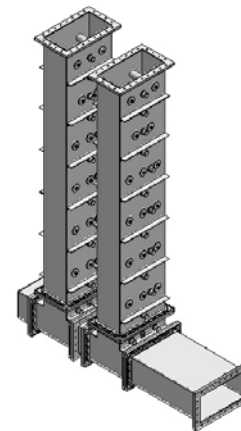
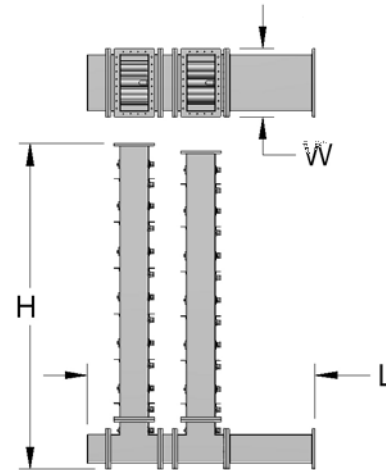

- Are used to combine two or more power amplifiers
- The single channel combiners are designed for all applications in UHF band, for standard channel bandwidths 6, 7 and 8 MHz and for custom bandwidths requirements

As standard single channel combiner type we do have available:

- **Switchless Combiner** that consists of a pair of phasers, a 3 dB hybrid, a magic TEE and a reject load. This device allows two power amplifiers on the same channel to combine in three different ways of operation with no off-air interruption in switching between the three modes:
 - AMP A + AMP B to antenna
 - AMP A to antenna and AMP B to reject load
 - AMP B to antenna and AMP A to reject load.

UHF Single Channel Combiners

Type	Frequency	Total Average Power	Mask Filters
Switchless	470-860 MHz	≤ 66 kW, 140 kW, 230 kW	ATV/DTV

Notes

DTV = Digital TV (ATSC/DVB/ISDB-T)

ATV = Analog TV (NTSC, PAL, SECAM)

MM = Mobile media

Specifications are subject to change without notice.

- Suitable for analog and digital TV applications
- Cost effective solution for a single channel combiner
- No "off air" time during switching
- Three modes of operation: TXA + TXB to antenna, TXA to antenna, TXB to antenna
- Low VSWR

Typical Specifications for 6 MHz TV Standard

Model Number	CU181S23	CU151S23	CU111S23
Total Average Power¹	230 kW	140 kW	66 kW
Frequency	470-494 MHz	494-680 MHz	650-860 MHz
Combiner Type²	Switchless combiner	Switchless combiner	Switchless combiner
Channel Spacing	Same channel	Same channel	Same channel

A, B Input

Average Power Handling	115 kW-115 kW	70 kW-70 kW	33 kW-33 kW
Insertion Loss	< 0.08 dB	< 0.08 dB	< 0.08 dB
Isolation Between Inputs	> 32 dB	> 32 dB	> 32 dB
VSWR	< 1.05	< 1.05	< 1.05
Connector	WR 1800/Coaxial EIA	WR 1500/Coaxial EIA	WR 1150/Coaxial EIA

Output Connector

Isolation Between Outputs (single modes)	> 32 dB	> 32 dB	> 32 dB
Material	Al	Al	Al
Connector	WR 1800/Coaxial EIA	WR 1500/Coaxial EIA	WR 1150/Coaxial EIA
Control Voltage	12 V DC or 24 V DC	12 V DC or 24 V DC	12 V DC or 24 V DC
Interlocks	DPDT each position	DPDT each position	DPDT each position
Ambient Temperature	32°F (0°C) to 114°F (45°C)	32°F (0°C) to 114°F (45°C)	32°F (0°C) to 114°F (45°C)
Storage Temperature	32°F (0°C) to 122°F (50°C)	32°F (0°C) to 122°F (50°C)	32°F (0°C) to 122°F (50°C)
Ambient/Storage Humidity	0-98%, non condensing	0-98%, non condensing	0-98%, non condensing
Dimensions (L x W x H)	150" x 67" x 35.5" (3.8 x 1.7 x 0.9 m)	138" x 55.3" x 34" (3.5 x 1.4 x 0.87 m)	115.3" x 39" x 30.5" (2.9 x 1 x 0.78 m)
Weight	1200 lbs (544 kg)	1030 lbs (467 kg)	855 lbs (388 kg)
Max. Altitude³	10,000 feet (3,050 m)	10,000 feet (3,050 m)	10,000 feet (3,050 m)
Application	ATV/DTV	ATV/DTV	ATV/DTV

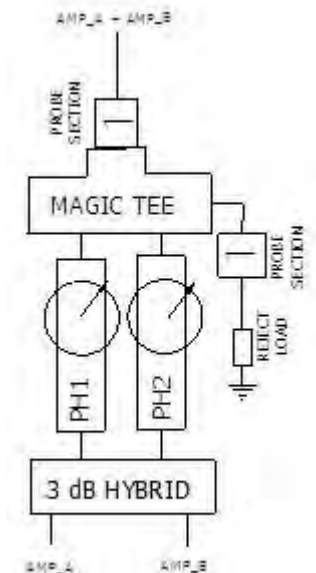
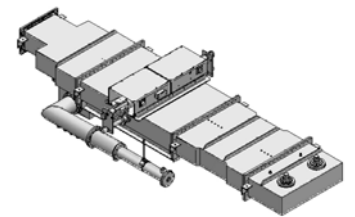
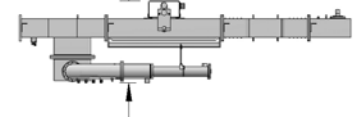
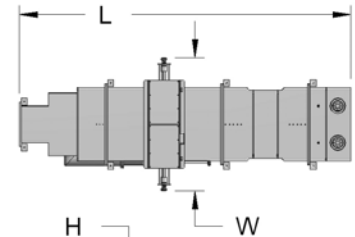

Notes

- 1) At ambient temperature 104°F (40°C, sea level, 0 PSIG). For higher power values, please contact the factory.
 - 2) Available as 3 dB or 4.77 dB combiner type
 - 3) For more than 5,000 feet (1,524 m), please contact the factory.
- Floor mounting frame available; please contact the factory.

Dielectric is the world's largest manufacturer of Rigid Coaxial Transmission Line. Our experience and record of reliable service, and superior quality, as well as our ongoing research and development programs have kept us the leader in our field. Dielectric manufactures rigid coaxial transmission lines in sizes ranging from 7/8" to 12". Outer conductor material is available in aluminum in certain sizes. More TV and radio stations, utilizing rigid Coax Transmission Line, are on the air with Dielectric.

Features

High Conductivity Copper

Dielectric's volume allows us to purchase entire mill runs (to our specifications) of high conductivity copper tubing, 95% ICAS/99.04% purity, providing Transmission Line of constant impedance and continuous high power capacity and low insertion loss.

Welded Construction

All of Dielectric's factory installed flanges and joints are Tungsten Inert Gas Welded to ensure structural integrity and long life.

Inner Conductor Support

Dielectric uses superior low loss PTFE disc type insulators (not pin or rod type supports) for long term reliability and service. Dielectric's line also utilizes a unique magneform process for insulator support undercuts. With magneforming, undercuts are magnetically formed rather than rolled or welded, allowing the use of a continuous inner conductor with excellent mechanical and electrical characteristics.

Heavy Wall Tubing

Dielectric uses heavy wall tubing in most miter elbows. In critical locations requiring extraordinary support, such as the bottom elbow on vertical runs, additional reinforcing is added.

Flanged

- For outdoor and indoor installation; includes the EIA standard

Unflanged

- For indoor installation only

EIA-Flanged Rigid Line

Size	Average Power*			
	108 MHz	230 MHz	776 MHz	860 MHz
1-5/8" EIA	≤ 15 kW	≤ 10 kW	N/A	≤ 5.4 kW
3-1/8" EIA	≤ 50 kW	≤ 33 kW	N/A	≤ 18 kW
6-1/8" EIA	≤ 170 kW	≤ 118 kW	≤ 63 kW	N/A

Flanged Rigid Line

Size	Average Power*			
	108 MHz	230 MHz	776 MHz	860 MHz
4-1/16"	≤ 80 kW	≤ 55.8 kW	N/A	≤ 28.7 kW

Unflanged Rigid Line

Size	Average Power*			
	108 MHz	230 MHz	776 MHz	860 MHz
1-5/8"	≤ 15 kW	≤ 10 kW	N/A	≤ 5 kW
3-1/8"	≤ 50 kW	≤ 33 kW	N/A	≤ 17 kW
4-1/16"	≤ 87 kW	≤ 57 kW	N/A	≤ 28 kW
6-1/8"	≤ 170 kW	≤ 118 kW	≤ 63 kW	N/A

Notes

*104°F (+40°C) ambient temperature, 145°F (63°C) outer temperature, 248°F (120°C) inner temperature, sea level, 0 PSIG, VSWR=1.0.

Sizes like: 75 Ohms, 6-1/8", 7-3/16", 8-3/16" and 9-3/16" for custom applications are available on request. Please call the factory for details.

Specifications are subject to change without notice.

Dielectric® Standard Coaxial 1-5/8" EIA Rigid Line Components

- Low insertion loss
- Low VSWR
- Outdoor/indoor applications
- Low loss PTFE® insulator
- Works in pressurized systems
- High conductivity Cu

Specifications

Impedance	50 ohms
Peak Voltage¹ at Sea Level	4.0 kV
Peak Power at Sea Level	320 kW
Frequency Range	0 ≤ F ≤ 1.0 GHz
Max. Altitude²	10,000 feet (3,050 m)
Ambient Temperature	32°F (0°C) to 113°F (45°C)
Storage Temperature	32°F (0°C) to 122°F (50°C)
Storage/Ambient Humidity	0-98% non condensing

Average Power³

108 MHz	≤ 15 kW
230 MHz	≤ 10 kW
860 MHz	≤ 5.4 kW

Loss/100 feet³

108 MHz	0.223 dB
230 MHz	0.305 dB
860 MHz	0.597 dB

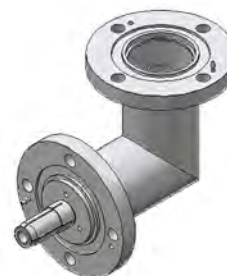
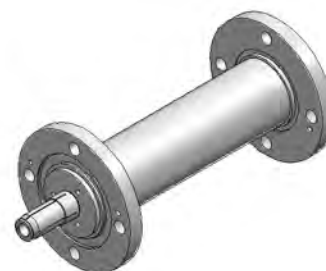

Notes

- 1) Peak voltage rating based on 4:1 margin of safety to theoretical. Peak power rating is calculated from peak voltage rating using the formula:

$$P_{pk} = (V_{pk})^2 / Z_0$$
- 2) For more than 5,000 feet (1,524 m), please consult the factory.
- 3) 104°F (+40°C) ambient temperature, 145°F (63°C) outer temperature, 248°F (120°C) inner temperature, sea level, 0 PSIG, VSWR=1.0
- 4) Transmission Line components must not be exposed to condensing moisture environments unless fully assembled and pressurized.
- 5) For outdoor applications, please contact the factory.

Straight Line Section – EIA Flanged

Model Number	Weight (per foot)	VSWR ² 108 MHz	VSWR ² 230 MHz	VSWR ² 860 MHz
DC 275-004	1.25 lbs ⁴ (0.57 kg)	1.03	1.03	1.05

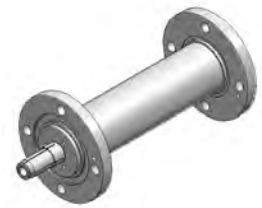
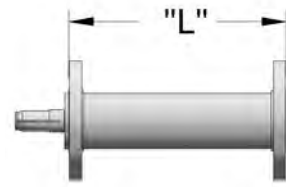

90° Equal Leg Elbow¹, swivel flanges

Model Number	Weight	VSWR ² 108 MHz	VSWR ² 230 MHz	VSWR ² 860 MHz
DC 275-017	3 lbs (1.36 kg)	1.03	1.03	1.03



90° Unequal Leg Elbow¹, swivel flanges

Model Number	Weight	VSWR ² 108 MHz	VSWR ² 230 MHz	VSWR ² 860 MHz
DC 275-018	4.25 lbs (1.93 kg)	1.03	1.03	1.03

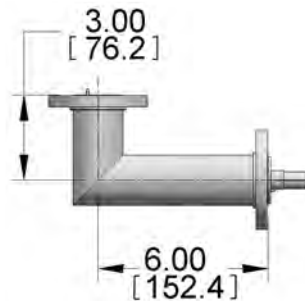

Soft Solder Flange³

Model Number	Weight
DC 270-014	2 lbs (0.9 kg)

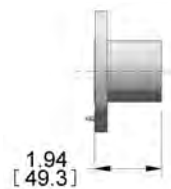

Anchor Inner Connector

Model Number	Weight	Notes
DC 275-011	3.5 oz (0.1 kg)	includes insulator

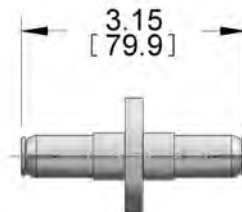

Notes

- 1) Includes Anchor Inner Connector, one O-ring and one hardware kit.
- 2) 104°F (+40°C) ambient temperature, 145°F (63°C) outer temperature, 248°F (120°C) inner temperature, sea level, 0 PSIG
- 3) Includes solder, liquid flux, brush, garnet paper and cleaner.
- 4) Does not include the weight of the flanges and anchor inner connector.

Dielectric® Standard Coaxial 3-1/8" EIA Rigid Line Components

- Low insertion loss
- Low VSWR
- Outdoor/indoor applications
- Low loss PTFE® insulator
- Works in pressurized systems
- High conductivity Cu

Specifications

Impedance	50 ohms
Peak Voltage¹ at Sea Level	7.8 kV
Peak Power at Sea Level	1,216.8 kW
Frequency Range	0 ≤ F ≤ 1.0 GHz
Max. Altitude²	10,000 feet (3,050 m)
Ambient Temperature	32°F (0°C) to 113°F (45°C)
Storage Temperature	32°F (0°C) to 122°F (50°C)
Storage/Ambient Humidity	0-98% non condensing

Average Power³

108MHz	≤ 50 kW
230MHz	≤ 35 kW
860MHz	≤ 18 kW

Loss/100 feet³

108MHz	0.103 dB
230MHz	0.147 dB
860MHz	0.287 dB



Notes

- 1) Peak voltage rating based on 4:1 margin of safety to theoretical. Peak power rating is calculated from peak voltage rating using the formula:

$$P_{pk} = (V_{pk})^2 / Z_0$$
- 2) For more than 5,000 feet (1,524 m), please consult the factory.
- 3) 104°F (+40°C) ambient temperature, 145°F (63°C) outer temperature, 248°F (120°C) inner temperature, sea level, 0 PSIG, VSWR=1.0
- 4) Transmission Line components must not be exposed to condensing moisture environments unless fully assembled and pressurized.
- 5) For outdoor applications, please contact the factory.

Straight Line Section – EIA Flanged

Model Number	Weight (per foot)	VSWR ² 108 MHz	VSWR ² 230 MHz	VSWR ² 860 MHz
DC 375-004	2.6 lbs ⁴ (1.2 kg)	1.03	1.03	1.03

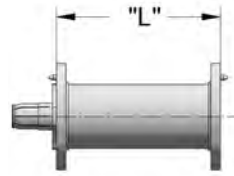

90° Equal Leg Elbow¹, swivel flanges

Model Number	Weight	VSWR ² 108 MHz	VSWR ² 230 MHz	VSWR ² 860 MHz
DC 375-017	9 lbs (4.08 kg)	1.03	1.03	1.03

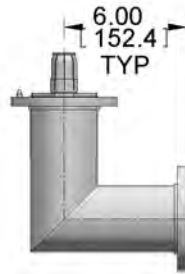

90° Unequal Leg Elbow¹, swivel flanges

Model Number	Weight	VSWR ² 108 MHz	VSWR ² 230 MHz	VSWR ² 860 MHz
DC 375-018	12 lbs (5.44 kg)	1.03	1.03	1.03

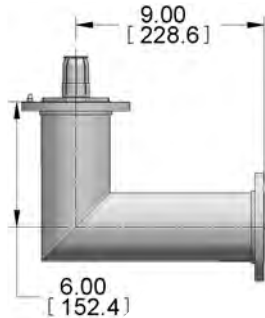

Soft Solder Flange³

Model Number	Weight
DC 370-014	3 lbs (1.36 kg)

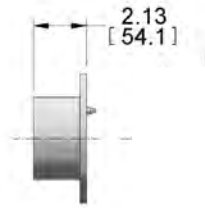

Anchor Inner Connector

Model Number	Weight	Notes
DC 375-011	13 oz (0.37 kg)	includes insulator



Notes

- 1) Includes Anchor Inner Connector, one O-ring and one hardware kit.
- 2) 104°F (+40°C) ambient temperature, 145°F (63°C) outer temperature, 248°F (120°C) inner temperature, sea level, 0 PSIG
- 3) Includes solder, liquid flux, brush, garnet paper and cleaner.
- 4) Does not include the weight of the flanges and anchor inner connector.

Specifications

Impedance	50 ohms
Peak Voltage¹ at Sea Level	11 kV
Peak Power at Sea Level	2,420 kW
Frequency Range	$0 \leq F \leq 1.0$ GHz
Max. Altitude²	10,000 feet (3,050 m)
Ambient Temperature	32°F (0°C) to 113°F (45°C)
Storage Temperature	32°F (0°C) to 122°F (50°C)
Storage/Ambient Humidity	0-98% non condensing

Average Power³

108 MHz	≤ 80 kW
230 MHz	≤ 55.8 kW
860 MHz	≤ 28.7 kW

Loss/100 feet³

108 MHz	0.079 dB
230 MHz	0.101 dB
860 MHz	0.198 dB



Notes

- 1) Peak voltage rating based on 4:1 margin of safety to theoretical. Peak power rating is calculated from peak voltage rating using the formula:

$$P_{pk} = (V_{pk})^2 / Z_0$$
- 2) For more than 5,000 feet (1,524 m), please consult the factory.
- 3) 104°F (+40°C) ambient temperature, 145°F (63°C) outer temperature, 248°F (120°C) inner temperature, sea level, 0 PSIG, VSWR=1.0
- 4) Transmission Line components must not be exposed to condensing moisture environments unless fully assembled and pressurized.
- 5) For outdoor applications, please contact the factory.

Straight Line Section – EIA Flanged

Model Number	Weight (per foot)	VSWR ² 108 MHz	VSWR ² 230 MHz	VSWR ² 860 MHz
DC 475-004	3.1 lbs ⁴ (1.4 kg)	1.03	1.03	1.03



90° Equal Leg Elbow¹, swivel flanges

Model Number	Weight	VSWR ² 108 MHz	VSWR ² 230 MHz	VSWR ² 860 MHz
DC 475-017	12 lbs (5.44 kg)	1.03	1.03	1.03

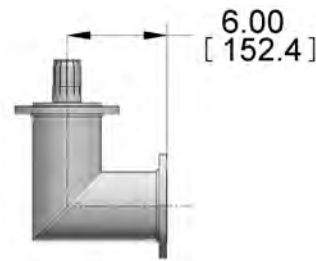

90° Unequal Leg Elbow¹, swivel flanges

Model Number	Weight	VSWR ² 108 MHz	VSWR ² 230 MHz	VSWR ² 860 MHz
DC 475-018	18 lbs (8.17 kg)	1.03	1.03	1.03

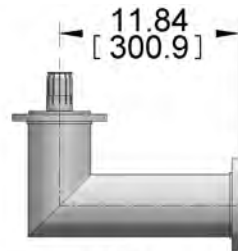

Soft Solder Flange³

Model Number	Weight
DC 470-014	6 lbs (2.72 kg)



Anchor Inner Connector

Model Number	Weight	Notes
DC 475-011	2 lbs (0.91 kg)	includes insulator

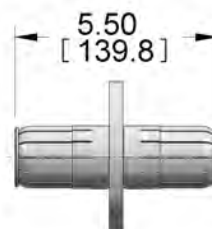

Notes

- 1) Includes Anchor Inner Connector, one O-ring and one hardware kit.
- 2) 104°F (+40°C) ambient temperature, 145°F (63°C) outer temperature, 248°F (120°C) inner temperature, sea level, 0 PSIG
- 3) Includes solder, liquid flux, brush, garnet paper and cleaner.
- 4) Does not include the weight of the flanges and anchor inner connector.

Dielectric® Standard Coaxial 6-1/8" EIA Rigid Line Components

- Low insertion loss
- Low VSWR
- Outdoor/indoor applications
- Low loss PTFE® insulator
- Works in pressurized systems
- High conductivity Cu

Specifications

Impedance	50 ohms
Peak Voltage¹ at Sea Level	15.6 kV
Peak Power at Sea Level	4,867.2 kW
Frequency Range	0 ≤ F ≤ 776 MHz
Max. Altitude²	10,000 feet (3,050 m)
Ambient Temperature	32°F (0°C) to 113°F (45°C)
Storage Temperature	32°F (0°C) to 122°F (50°C)
Storage/Ambient Humidity	0-98% non condensing

Average Power³

108 MHz	≤ 170 kW
230 MHz	≤ 118 kW
776 MHz	≤ 63 kW

Loss/100 feet³

108 MHz	0.054 dB
230 MHz	0.078 dB
776 MHz	0.152 dB



Notes

- 1) Peak voltage rating based on 4:1 margin of safety to theoretical. Peak power rating is calculated from peak voltage rating using the formula:

$$P_{pk} = (V_{pk})^2 / Z_0$$
- 2) For more than 5,000 feet (1,524 m), please consult the factory.
- 3) 104°F (+40°C) ambient temperature, 145°F (63°C) outer temperature, 248°F (120°C) inner temperature, sea level, 0 PSIG, VSWR=1.0
- 4) Transmission Line components must not be exposed to condensing moisture environments unless fully assembled and pressurized.
- 5) For outdoor applications, please contact the factory.

Straight Line Section – EIA Flanged

Model Number	Weight (per foot)	VSWR ² 108 MHz	VSWR ² 230 MHz	VSWR ² 776 MHz
DC 675-004	3.35 lbs ⁴ (1.52 kg)	1.03	1.03	1.03

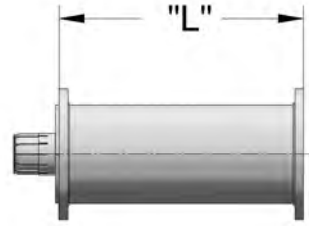

90° Equal Leg Elbow¹, swivel flanges

Model Number	Weight	VSWR ² 108 MHz	VSWR ² 230 MHz	VSWR ² 776 MHz
DC 675-017	28 lbs (12.7 kg)	1.03	1.03	1.03

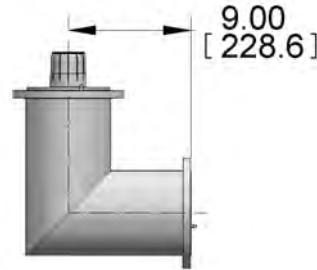

90° Unequal Leg Elbow¹, swivel flanges

Model Number	Weight	VSWR ² 108 MHz	VSWR ² 230 MHz	VSWR ² 776 MHz
DC 675-018	31 lbs (14.06 kg)	1.03	1.03	1.03

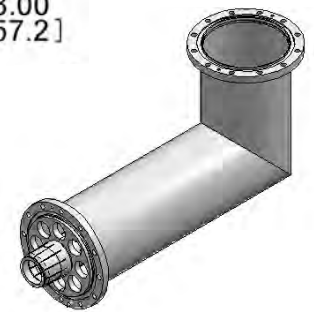
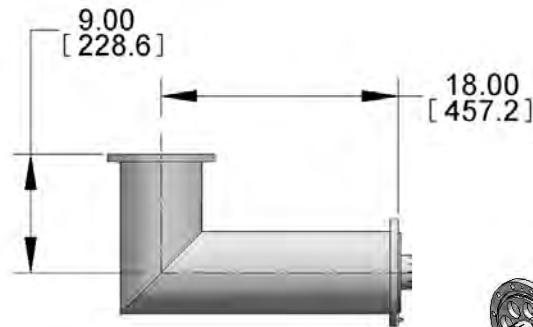

Soft Solder Flange³

Model Number	Weight
DC 670-014	7 lbs (3.18 kg)



Anchor Inner Connector

Model Number	Weight	Notes
DC 675-011	2 lbs (0.91 kg)	includes insulator



Notes

- 1) Includes Anchor Inner Connector, one O-ring and one hardware kit.
- 2) 104°F (+40°C) ambient temperature, 145°F (63°C) outer temperature, 248°F (120°C) inner temperature, sea level, 0 PSIG
- 3) Includes solder, liquid flux, brush, garnet paper and cleaner.
- 4) Does not include the weight of the flanges and anchor inner connector.

Dielectric® Standard Coaxial 1-5/8" Unflanged Rigid Line Components

- Low insertion loss
- Low VSWR
- Indoor applications
- Easy installation
- Low loss PTFE® insulator
- High conductivity Cu

Specifications

Impedance	50 ohms
Peak Voltage¹ at Sea Level	4 kV
Peak Power at Sea Level	320 kW
Frequency Range	$0 \leq F \leq 1.0$ GHz
Max. Altitude²	10,000 feet (3,050 m)
Ambient Temperature	32°F (0°C) to 113°F (45°C)
Storage Temperature	32°F (0°C) to 122°F (50°C)
Storage/Ambient Humidity	0-98% non condensing

Average Power³

108 MHz	≤ 15 kW
230 MHz	≤ 10 kW
860 MHz	≤ 5 kW

Loss/100 feet³

108 MHz	0.223 dB
230 MHz	0.305 dB
860 MHz	0.597 dB

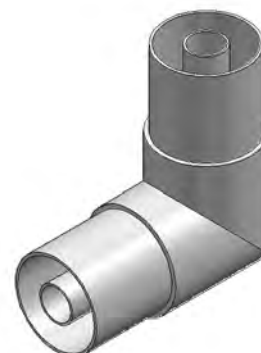

Notes

- 1) Peak voltage rating based on 4:1 margin of safety to theoretical.
- 2) For more than 5,000 feet (1,524 m), please consult the factory.
- 3) 104°F (+40°C) ambient temperature, 145°F (63°C) outer temperature, 248°F (120°C) inner temperature, sea level, 0 PSIG, VSWR=1.0
- 4) Transmission Line components must not be exposed to condensing moisture environments unless fully assembled and pressurized.
- 5) For outdoor applications, please contact the factory.

Straight Line Section – Unflanged

Model Number	Weight (per foot)	VSWR ¹ 108 MHz	VSWR ¹ 230 MHz	VSWR ¹ 860 MHz
DC 265-002	1.25 lbs (0.57 kg)	1.03	1.03	1.05

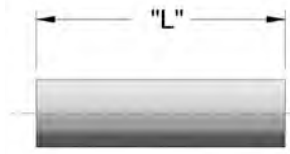

90° Equal Leg Elbow

Model Number	Weight	VSWR ¹ 108 MHz	VSWR ¹ 230 MHz	VSWR ¹ 860 MHz
DC 265-017	1.75 lbs (0.8 kg)	1.03	1.03	1.03

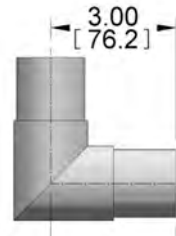

90° Unequal Leg Elbow

Model Number	Weight	VSWR ¹ 108 MHz	VSWR ¹ 230 MHz	VSWR ¹ 860 MHz
DC 265-018	3 lbs (1.36 kg)	1.03	1.03	1.03

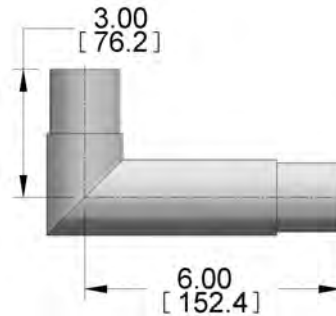

Unflanged Coupling²

Model Number	Weight
DC 265-008	0.5 lb (0.227 kg)



Anchor Inner Connector

Model Number	Weight	Notes
DC 265-007	2 oz (0.06 kg)	includes insulator

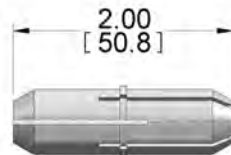

Notes

- 1) 104°F (+40°C) ambient temperature, 248°F (120°C) inner temperature, sea level, 0 PSIG.
- 2) Includes one Anchor Inner Connector, and two hose clamps.

- Low insertion loss
- Low VSWR
- Indoor applications
- Easy installation
- Low loss PTFE® insulator
- High conductivity Cu

Specifications

Impedance	50 ohms
Peak Voltage¹ at Sea Level	7.8 kV
Peak Power at Sea Level	1,216.8 kW
Frequency Range	0 ≤ F ≤ 1.0 GHz
Max. Altitude²	10,000 feet (3,050 m)
Ambient Temperature	32°F (0°C) to 113°F (45°C)
Storage Temperature	32°F (0°C) to 113°F (45°C)
Storage/Ambient Humidity	0-98% non condensing

Average Power³

108MHz	≤ 50 kW
230MHz	≤ 33 kW
860MHz	≤ 17 kW

Loss/100 feet³

108MHz	0.103 dB
230MHz	0.147 dB
860MHz	0.287 dB

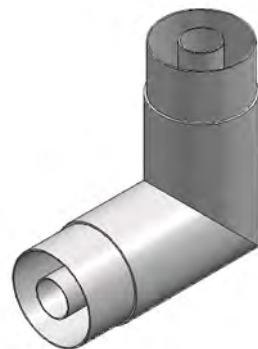

Notes

- 1) Peak voltage rating based on 4:1 margin of safety to theoretical.
- 2) For more than 5,000 feet (1,524 m), please consult the factory.
- 3) 104°F (+40°C) ambient temperature, 145°F (63°C) outer temperature, 248°F (120°C) inner temperature, sea level, 0 PSIG, VSWR=1.0
- 4) Transmission Line components must not be exposed to condensing moisture environments unless fully assembled and pressurized.
- 5) For outdoor applications, please contact the factory.

Straight Line Section – Unflanged

Model Number	Weight (per foot)	VSWR ¹ 108 MHz	VSWR ¹ 230 MHz	VSWR ¹ 860 MHz
DC 365-002	2.6 lbs (1.2 kg)	1.03	1.03	1.03

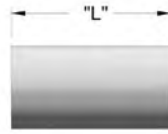

90° Equal Leg Elbow

Model Number	Weight	VSWR ¹ 108 MHz	VSWR ¹ 230 MHz	VSWR ¹ 860 MHz
DC 365-017	4 lbs (1.81 kg)	1.03	1.03	1.03

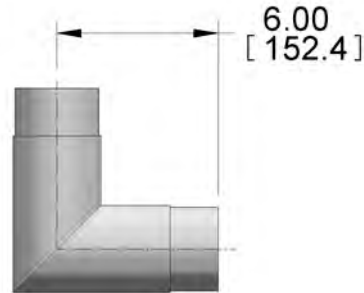

90° Unequal Leg Elbow

Model Number	Weight	VSWR ¹ 108 MHz	VSWR ¹ 230 MHz	VSWR ¹ 860 MHz
DC 365-018	6 lbs (2.72 kg)	1.03	1.03	1.03

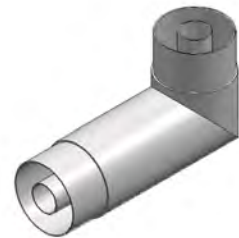
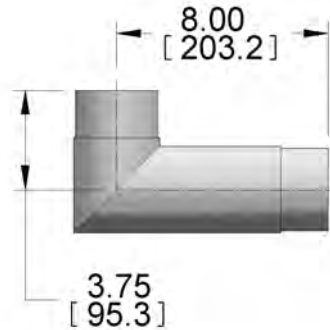

Unflanged Coupling²

Model Number	Weight
DC 365-008	1 lb (0.453 kg)



Anchor Inner Connector

Model Number	Weight	Notes
DC 365-007	3 oz (0.09 kg)	includes insulator

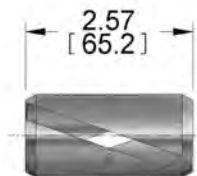

Notes

- 1) 104°F (+40°C) ambient temperature, 248°F (120°C) inner temperature, sea level, 0 PSIG.
- 2) Includes one Anchor Inner Connector, and two hose clamps.

Dielectric® Standard Coaxial 4-1/16" Unflanged Rigid Line Components

- Low insertion loss
- Low VSWR
- Indoor applications
- Easy installation
- Low loss PTFE® insulator
- High conductivity Cu

Specifications

Impedance	50 ohms
Peak Voltage¹ at Sea Level	11 kV
Peak Power at Sea Level	2,420 kW
Frequency Range	$0 \leq F \leq 1.0$ GHz
Max. Altitude²	10,000 feet (3,050 m)
Ambient Temperature	32°F (0°C) to 113°F (45°C)
Storage Temperature	32°F (0°C) to 122°F (50°C)
Storage/Ambient Humidity	0-98% non condensing

Average Power³

108 MHz	≤ 87 kW
230 MHz	≤ 57 kW
860 MHz	≤ 28 kW

Loss/100 feet³

108 MHz	0.079 dB
230 MHz	0.101 dB
860 MHz	0.198 dB

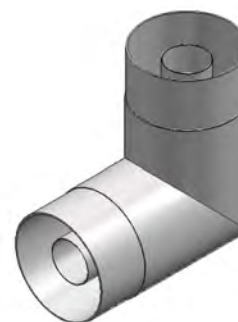

Notes

- 1) Peak voltage rating based on 4:1 margin of safety to theoretical.
- 2) For more than 5,000 feet (1,524 m), please consult the factory.
- 3) 104°F (+40°C) ambient temperature, 145°F (63°C) outer temperature, 248°F (120°C) inner temperature, sea level, 0 PSIG, VSWR=1.0
- 4) Transmission Line components must not be exposed to condensing moisture environments unless fully assembled and pressurized.
- 5) For outdoor applications, please contact the factory.

Straight Line Section – Unflanged

Model Number	Weight (per foot)	VSWR ¹ 108 MHz	VSWR ¹ 230 MHz	VSWR ¹ 860 MHz
DC 465-002	3.1 lbs (1.4 kg)	1.03	1.03	1.03

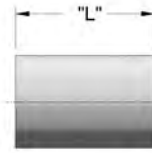

90° Equal Leg Elbow

Model Number	Weight	VSWR ¹ 108 MHz	VSWR ¹ 230 MHz	VSWR ¹ 860 MHz
DC 465-017	5 lbs (2.27 kg)	1.03	1.03	1.03

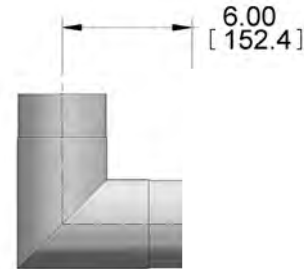

90° Unequal Leg Elbow

Model Number	Weight	VSWR ¹ 108 MHz	VSWR ¹ 230 MHz	VSWR ¹ 860 MHz
DC 465-018	7 lbs (3.18 kg)	1.03	1.03	1.03

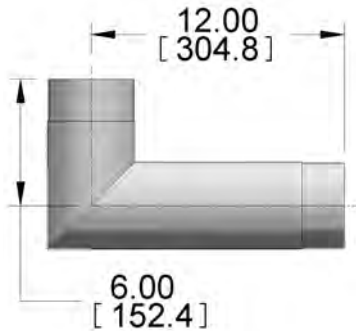

Unflanged Coupling²

Model Number	Weight
DC 465-008	2 lbs (0.91 kg)

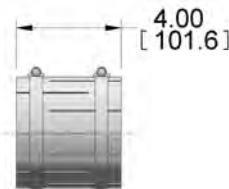

Anchor Inner Connector

Model Number	Weight	Notes
DC 465-007	4 oz (0.11 kg)	includes insulator

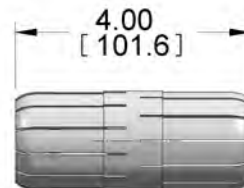

Notes

- 1) 104°F (+40°C) ambient temperature, 248°F (120°C) inner temperature, sea level, 0 PSIG.
- 2) Includes one Anchor Inner Connector, and two hose clamps.

- Low insertion loss
- Low VSWR
- Indoor applications
- Easy installation
- Low loss PTFE® insulator
- High conductivity Cu

Specifications

Impedance	50 ohms
Peak Voltage¹ at Sea Level	15.6 kV
Peak Power at Sea Level	4,867.2 kW
Frequency Range	0 ≤ F ≤ 776 MHz
Max. Altitude²	10,000 feet (3,050 m)
Ambient Temperature	32°F (0°C) to 113°F (45°C)
Storage Temperature	32°F (0°C) to 122°F (50°C)
Storage/Ambient Humidity	0-98% non condensing

Average Power³

108 MHz	≤ 170 kW
230 MHz	≤ 118 kW
776 MHz	≤ 63 kW

Loss/100 feet³

108 MHz	0.054 dB
230 MHz	0.078 dB
776 MHz	0.152 dB

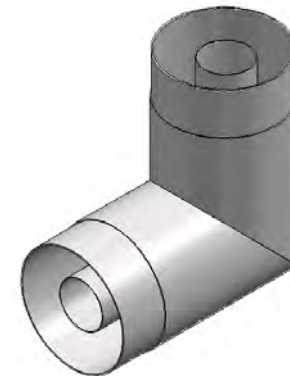
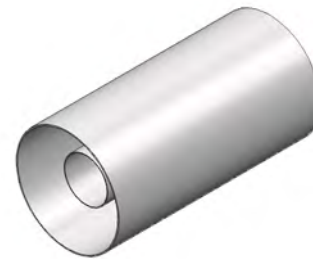

Notes

- 1) Peak voltage rating based on 4:1 margin of safety to theoretical.
- 2) For more than 5,000 feet (1,524 m), please consult the factory.
- 3) 104°F (+40°C) ambient temperature, 145°F (63°C) outer temperature, 248°F (120°C) inner temperature, sea level, 0 PSIG, VSWR=1.0
- 4) Transmission Line components must not be exposed to condensing moisture environments unless fully assembled and pressurized.
- 5) For outdoor applications, please contact the factory.

Straight Line Section – Unflanged

Model Number	Weight (per foot)	VSWR ¹ 108 MHz	VSWR ¹ 230 MHz	VSWR ¹ 776 MHz
DC 665-002	3.35 lbs (1.52 kg)	1.03	1.03	1.03

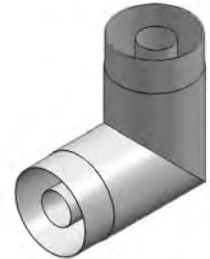
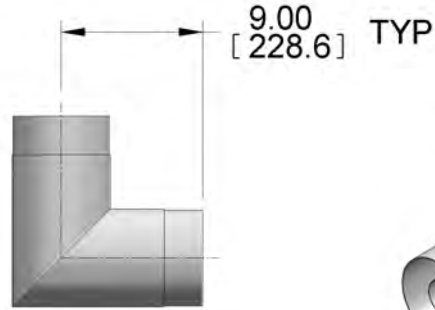
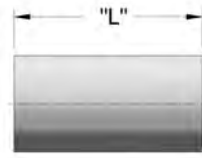

90° Equal Leg Elbow

Model Number	Weight	VSWR ¹ 108 MHz	VSWR ¹ 230 MHz	VSWR ¹ 776 MHz
DC 665-017	13 lbs (5.9 kg)	1.03	1.03	1.03

90° Unequal Leg Elbow

Model Number	Weight	VSWR ¹ 108 MHz	VSWR ¹ 230 MHz	VSWR ¹ 776 MHz
DC 665-018	22 lbs (9.98 kg)	1.03	1.03	1.03

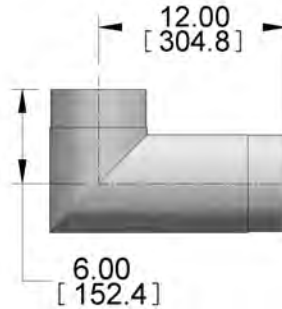

Unflanged Coupling²

Model Number	Weight
DC 665-008	4 lbs (1.82 kg)



Anchor Inner Connector

Model Number	Weight	Notes
DC 665-007	8 oz (0.227 kg)	includes insulator



Notes

- 1) 104°F (+40°C) ambient temperature, 248°F (120°C) inner temperature, sea level, 0 PSIG.
- 2) Includes one Anchor Inner Connector, and two hose clamps.

- Used for patching or break transmitter's paths in single, half, back-up, etc.
- Used to patch the transmitter's output to dummy load, between main and standby antennas, bypassing intermediate RF systems (combiners, splitters, etc.)
- The switch is carry-on manually with U-links help
- Interlock switches included
- Input/output connectors are on the back of the patch panels
- Low-cost alternative to multi connection routing situations

Notes

Dielectric can design and supply coaxial patch panels in custom configurations for special requirements.

3-Port

Size	Average Power*		
	108 MHz	230 MHz	860 MHz
1-5/8" EIA	≤ 15 kW	≤ 10 kW	≤ 5.4 kW
3-1/8" EIA	≤ 50 kW	≤ 35 kW	≤ 18 kW
4-1/16" FLG	≤ 80 kW	≤ 57.8 kW	≤ 28.7 kW

4-Port

Size	Average Power*		
	108 MHz	230 MHz	860 MHz
1-5/8" EIA	≤ 15 kW	≤ 10 kW	≤ 5.4 kW
3-1/8" EIA	≤ 50 kW	≤ 35 kW	≤ 18 kW
4-1/16" FLG	≤ 80 kW	≤ 57.8 kW	≤ 28.7 kW

5-Port

Size	Average Power*		
	108 MHz	230 MHz	860 MHz
1-5/8" EIA	≤ 15 kW	≤ 10 kW	≤ 5.4 kW
3-1/8" EIA	≤ 50 kW	≤ 35 kW	≤ 18 kW
4-1/16" FLG	≤ 80 kW	≤ 57.8 kW	≤ 28.7 kW

7-Port

Size	Average Power*		
	108 MHz	230 MHz	860 MHz
1-5/8" EIA	≤ 15 kW	≤ 10 kW	≤ 5.4 kW
3-1/8" EIA	≤ 50 kW	≤ 35 kW	≤ 18 kW
4-1/16" FLG	≤ 80 kW	≤ 57.8 kW	≤ 28.7 kW

Notes

* 104°F (+40°C) ambient temperature, 145°F (63°C) outer temperature, 248°F (120°C) inner temperature, sea level, 0 PSIG, VSWR=1.0

More switching ports and different sizes like: 75 Ohms, 6-1/8", 7-3/16", 8-3/16" and 9-3/16" for custom applications are available on request. Please call the factory for details.

Specifications are subject to change without notice.

- Low insertion loss
- Low VSWR
- Indoor applications
- Manual switching with U-link
- DPDT interlocks for customer's RF interlocking

Specifications

Model Number	DC 285-431	DC 385-431	DC 485-431
Input/output Connectors	1-5/8" EIA	3-1/8" EIA	4-1/16" FLG
Impedance	50 ohms	50 ohms	50 ohms
Frequency Range	0-860 MHz	0-860 MHz	0-860 MHz
Peak Voltage at Sea Level	4 kV	7.8 kV	11 kV
Max. Altitude¹	10,000 feet (3,050 m)	10,000 feet (3,050 m)	10,000 feet (3,050 m)
Ambient Temperature	32°F (0°C) to 113°F (45°C)	32°F (0°C) to 113°F (45°C)	32°F (0°C) to 113°F (45°C)
Storage Temperature	32°F (0°C) to 122°F (50°C)	32°F (0°C) to 122°F (50°C)	32°F (0°C) to 122°F (50°C)
Storage/Ambient Humidity²	0-98% non condensing	0-98% non condensing	0-98% non condensing

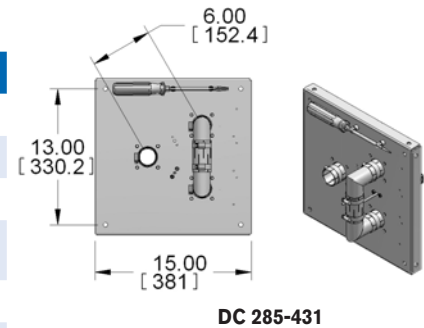

Average Power³

108 MHz	≤ 15 kW	≤ 50 kW	≤ 80 kW
230 MHz	≤ 10 kW	≤ 35 kW	≤ 57.8 kW
860 MHz	≤ 5.4 kW	≤ 18 kW	≤ 28.7 kW

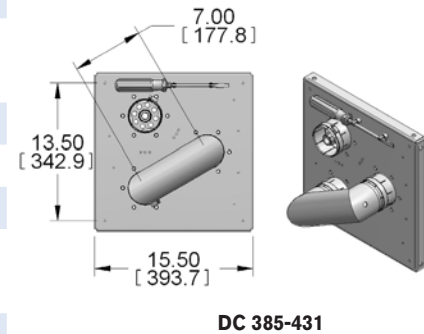

Insertion Loss	≤ 0.1 dB	≤ 0.1 dB	≤ 0.1 dB
VSWR	≤ 1.05	≤ 1.05	≤ 1.05
U-link	1 of 1-5/8"	1 of 3-1/8"	1 of 4-1/16"
Number of Interlock Contacts	3	3	3

Loading of Interlock Contacts

Operating Voltage	≤ 125 V AC	≤ 125 V AC	≤ 125 V AC
Operating Current	≤ 8 A	≤ 8 A	≤ 8 A

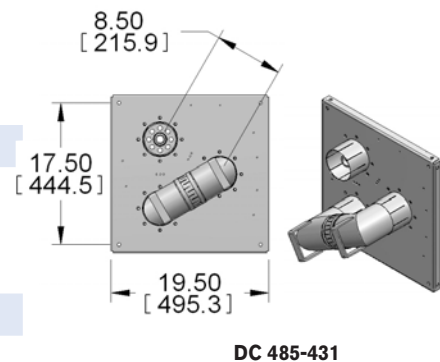

Weight (with U-link)	40 lbs (18.2 kg)	65 lbs (29.5 kg)	105 lbs (47.7 kg)
-----------------------------	------------------	------------------	-------------------

Notes

- 1) For more than 5,000 feet (1,524 m), please contact the factory.
- 2) Patch panels must not be exposed to condensing moisture environments.
- 3) 104°F (+40°C) ambient temperature, 145°F (63°C) outer temperature, 248°F (120°C) inner temperature sea level, 0 PSIG, VSWR=1.0

- Low insertion loss
- Low VSWR
- Indoor applications
- Manual switching with U-link
- DPDT interlocks for customer's RF interlocking

Specifications

Model Number	DC 285-441	DC 385-441	DC 485-441
Input/output Connectors	1-5/8" EIA	3-1/8" EIA	4-1/16" FLG
Impedance	50 ohms	50 ohms	50 ohms
Frequency Range	0-860 MHz	0-860 MHz	0-860 MHz
Peak Voltage at Sea Level	4 kV	7.8 kV	11 kV
Max. Altitude¹	10,000 feet (3,050 m)	10,000 feet (3,050 m)	10,000 feet (3,050 m)
Ambient Temperature	32°F (0°C) to 113°F (45°C)	32°F (0°C) to 113°F (45°C)	32°F (0°C) to 113°F (45°C)
Storage Temperature	32°F (0°C) to 122°F (50°C)	32°F (0°C) to 122°F (50°C)	32°F (0°C) to 122°F (50°C)
Storage/Ambient Humidity²	0-98% non condensing	0-98% non condensing	0-98% non condensing

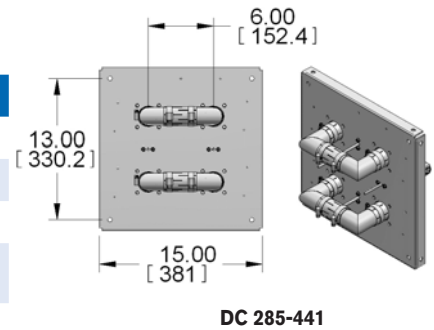

Average Power³

108 MHz	≤ 15 kW	≤ 50 kW	≤ 80 kW
230 MHz	≤ 10 kW	≤ 35 kW	≤ 57.8 kW
860 MHz	≤ 5.4 kW	≤ 18 kW	≤ 28.7 kW

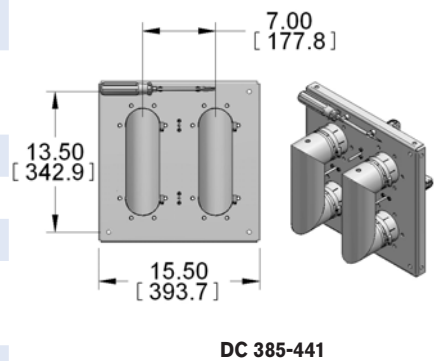

Insertion Loss	≤ 0.1 dB	≤ 0.1 dB	≤ 0.1 dB
VSWR	≤ 1.05	≤ 1.05	≤ 1.05
U-link	2 of 1-5/8"	2 of 3-1/8"	2 of 4-1/16"
Number of Interlock Contacts	4	4	4

Loading of Interlock Contacts

Operating Voltage	≤ 125 V AC	≤ 125 V AC	≤ 125 V AC
Operating Current	≤ 8 A	≤ 8 A	≤ 8 A

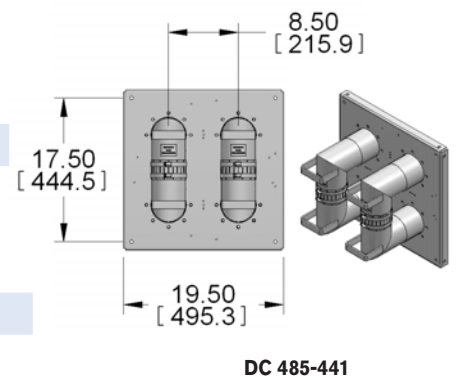

Weight (with U-link)	65 lbs (29.5 kg)	100 lbs (45.4 kg)	215 lbs (97.5 kg)
-----------------------------	------------------	-------------------	-------------------

Notes

- 1) For more than 5,000 feet (1,524 m), please contact the factory.
- 2) Patch panels must not be exposed to condensing moisture environments.
- 3) 104°F (+40°C) ambient temperature, 145°F (63°C) outer temperature, 248°F (120°C) inner temperature sea level, 0 PSIG, VSWR=1.0

- Low insertion loss
- Low VSWR
- Indoor applications
- Manual switching with U-link
- DPDT interlocks for customer's RF interlocking

- 1) For more than 5,000 feet (1,524 m), please contact the factory.
- 2) Patch panels must not be exposed to condensing moisture environments.
- 3) 104°F (+40°C) ambient temperature, 145°F (63°C) outer temperature, 248°F (120°C) inner temperature sea level, 0 PSIG, VSWR= 1.0

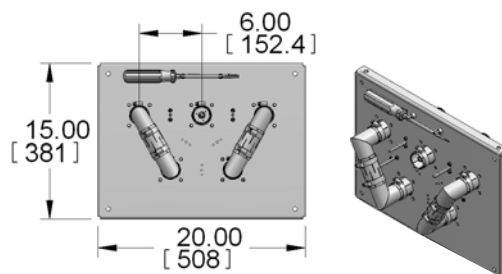

DC 285-451

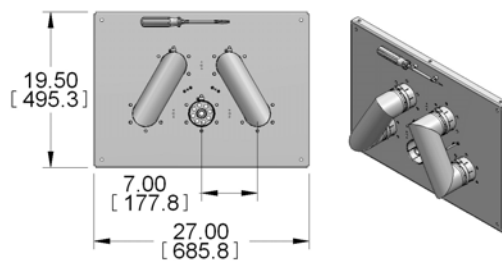

DC 385-451

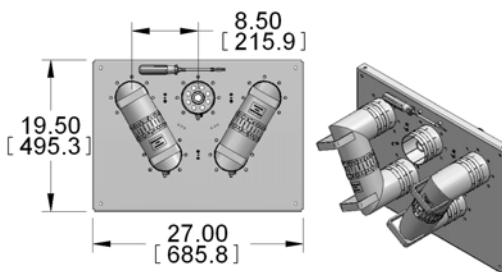

DC 485-451

- Low insertion loss
- Low VSWR
- Indoor applications
- Manual switching with U-link
- DPDT interlocks for customer's RF interlocking

Specifications

Model Number	DC 285-471	DC 385-471	DC 485-471
Input/output Connectors	1-5/8" EIA	3-1/8" EIA	4-1/16" FLG
Impedance	50 ohms	50 ohms	50 ohms
Frequency Range	0-860 MHz	0-860 MHz	0-860 MHz
Peak Voltage at Sea Level	4 kV	7.8 kV	11 kV
Max. Altitude¹	10,000 feet (3,050 m)	10,000 feet (3,050 m)	10,000 feet (3,050 m)
Ambient Temperature	32°F (0°C) to 113°F (45°C)	32°F (0°C) to 113°F (45°C)	32°F (0°C) to 113°F (45°C)
Storage Temperature	32°F (0°C) to 122°F (50°C)	32°F (0°C) to 122°F (50°C)	32°F (0°C) to 122°F (50°C)
Storage/Ambient Humidity²	0-98% non condensing	0-98% non condensing	0-98% non condensing

Average Power³

108 MHz	≤ 15 kW	≤ 50 kW	≤ 80 kW
230 MHz	≤ 10 kW	≤ 35 kW	≤ 57.8 kW
860 MHz	≤ 5.4 kW	≤ 18 kW	≤ 28.7 kW

Insertion Loss	≤ 0.1 dB	≤ 0.1 dB	≤ 0.1 dB
VSWR	≤ 1.05	≤ 1.05	≤ 1.05
U-link	3 of 1-5/8"	3 of 3-1/8"	3 of 4-1/16"
Number of Interlock Contacts	11	11	11

Loading of Interlock Contacts

Operating Voltage	≤ 125 V AC	≤ 125 V AC	≤ 125 V AC
Operating Current	≤ 8 A	≤ 8 A	≤ 8 A

Weight (with U-link)	85 lbs (38.6 kg)	165 lbs (75 kg)	310 lbs (140.6 kg)
-----------------------------	------------------	-----------------	--------------------

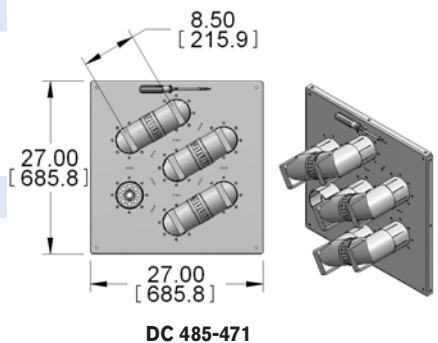
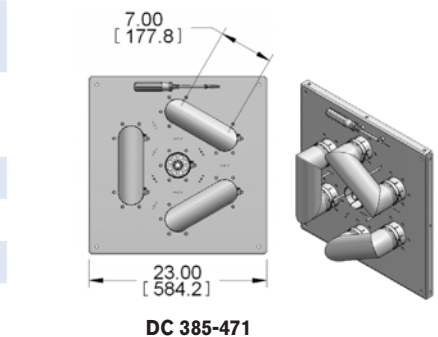
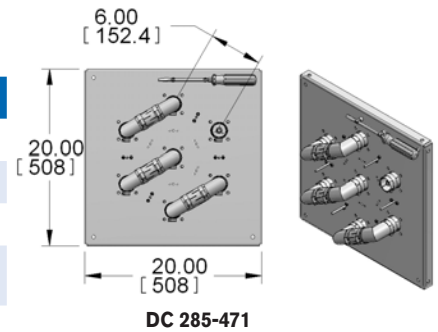

Notes

- 1) For more than 5,000 feet (1,524 m), please contact the factory.
- 2) Patch panels must not be exposed to condensing moisture environments.
- 3) 104°F (+40°C) ambient temperature, 145°F (63°C) outer temperature, 248°F (120°C) inner temperature sea level, 0 PSIG, VSWR=1.0

Leading the broadcast industry for over a half century.

Founded in 1942, Dielectric continues to be at the forefront of RF component design and manufacture. Whether the transmission format is analog or digital, Dielectric's conservative design philosophy will ensure the highest quality and most reliable products are available to you, our customer.

Quality components keep you on the air.

For the broadcaster, every second off the air is lost revenue. Therefore, each component in your broadcast system must be of the highest quality available. Dielectric's reputation for engineering excellence is recognized throughout the world. When emergency parts or services are needed, you can count on Dielectric to provide assistance and help to get you back on the air.

Reliability is everything.

Keeping the signal transmitting without interruption is the result of system components designed to the highest standards. The 50000 Series motorized coaxial switch introduced in 1978 has become the standard in the industry for its reliability and unmatched isolation characteristics.

We've recently enhanced our popular 50000 Series switch, and created the 60000 Series switch. The 60000 series switch is using single pole double throw type limit switches, used for readout and position indication. They ensure that the switch is always in the correct position.

In addition, the 60000 Series switch may be operated locally with no customer input wiring, a distinct advantage for simple system set up and maintenance. The 60000 Series switch is a direct drop in replacement for existing 50000 Series switches.

Features

- Used to automatically patch the transmitter's output to dummy load, between main and standby antennas, bypassing intermediate RF systems (combiners, splitters, etc.)
- Switching is accomplished using a motor drive. Manual option is also available which is especially useful in emergency situations.
- Simple setup and maintenance
- Pressurized upon request
- Remote control option
- 12/24 VDC or 115/230 VAC control voltage options available with no field modifications

4-Port

Size	Frequency Range	Average Power*				Motor Drive
		108 MHz	230 MHz	776 MHz	860 MHz	
1-5/8" EIA	DC 900MHz	≤ 12.1 kW	≤ 8.3 kW	≤ 4.5 kW	≤ 4.3 kW	115/230 V AC, 60/50 Hz
3-1/8" EIA	DC 900MHz	≤ 40.5 kW	≤ 28 kW	≤ 15.1 kW	≤ 14.4 kW	115/230 V AC, 60/50 Hz
4-1/16" FLA	DC 800MHz	≤ 64.7 kW	≤ 44.6 kW	≤ 24.1 kW	≤ 22.9 kW	115/230 V AC, 60/50 Hz
6-1/8" EIA	DC 800MHz	≤ 136.3 kW	≤ 94.1 kW	≤ 50.7 kW	N/A	115/230 V AC, 60/50 Hz

Notes

*104°F (+40°C) ambient temperature, 145°F (63°C) outer temperature, 248°F (120°C) inner temperature, sea level, 0 PSIG, VSWR=1.0.

Specifications are subject to change without notice.

- Low insertion loss
- Low VSWR
- Motor drive switching
- Indoor applications
- Emergency manual operation
- Pressurized upon request
- Two-way switches

Specifications

Model Number	DC 60000-200	DC 60000-205
Input/Output Connectors	1-5/8" EIA	1-5/8" EIA
Impedance	50 ohms	50 ohms
Peak Voltage⁴ at Sea Level	4.5 kV	4.5 kV
Frequency Range¹	DC 900 MHz	DC 900 MHz
Max. Altitude²	10,000 feet (3,050 m)	10,000 feet (3,050 m)
Ambient Temperature	32°F (0°C) to 113°F (45°C)	32°F (0°C) to 113°F (45°C)
Storage Temperature	32°F (0°C) to 122°F (50°C)	32°F (0°C) to 122°F (50°C)
Storage/ Ambient Humidity³	0-98% non condensing	0-98% non condensing

Average Power⁴

108 MHz	≤ 12.1 kW	≤ 12.1 kW
230 MHz	≤ 8.3 kW	≤ 8.3 kW
776 MHz	≤ 4.5 kW	≤ 4.5 kW
860 MHz	≤ 4.3 kW	≤ 4.3 kW
Insertion Loss	≤ 0.1 dB	≤ 0.1 dB
VSWR	≤ 1.05	≤ 1.05
Isolation	> 60 dB	> 60 dB
Switching Time	3 sec.	3 sec.

Electrical Data

Motor Operating Voltage	115 V AC/50/60 Hz	230 V AC/50/60 Hz
Motor Operating Current	1.25 Amps-start 0.6 Amps-run	0.924 Amps-start 0.50 Amps-run
Control Voltage	12/24 V DC, 115/230 V AC	12/24 V DC, 115/230 V AC

Limit Switches Rating⁵

Voltage	125/230 V AC	125/230 V AC
Current	1/3HP, 10 Amps	1/3HP, 10 Amps
Weight	42 lbs (19 kg)	42 lbs (19 kg)

Notes

- 1) Special operating frequency requests beyond specified operating range accepted. Call factory for details.
- 2) For more than 5,000 feet (1,524 m), please consult the factory.
- 3) Coaxial switches must not to be exposed to condensing moisture environments.
- 4) 104°F (+40°C) ambient temperature, 145°F (63°C) outer temperature, 248°F (120°C) inner temperature, sea level, 0 PSIG, VSWR=1.0
- 5) Limit Switches are used for readout and position indication.

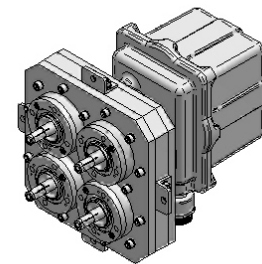
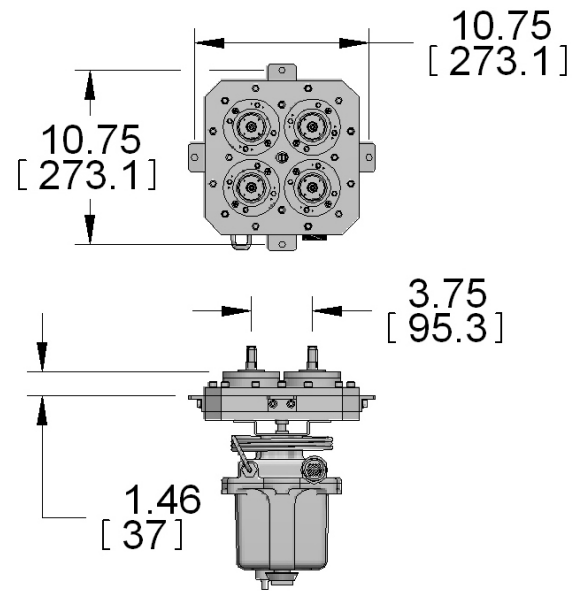

Control and Monitor Connector Pin Assignment Diagram

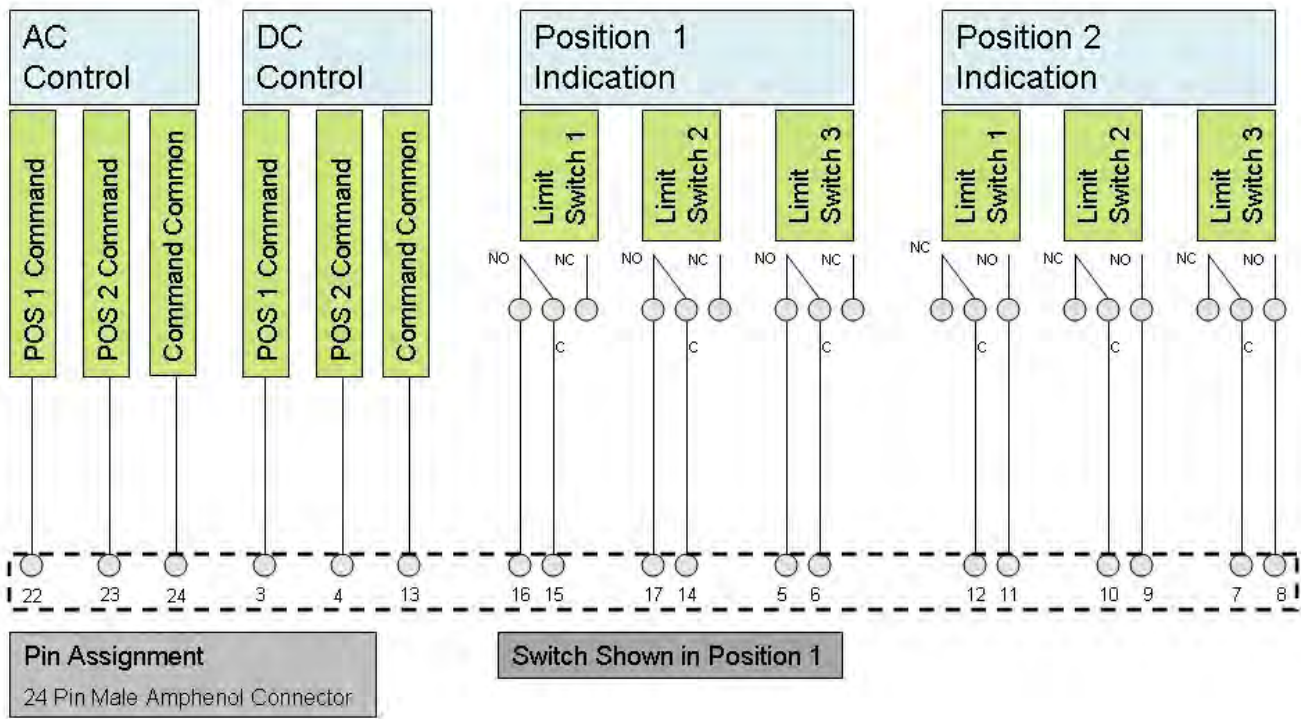

Electrical Block Diagram

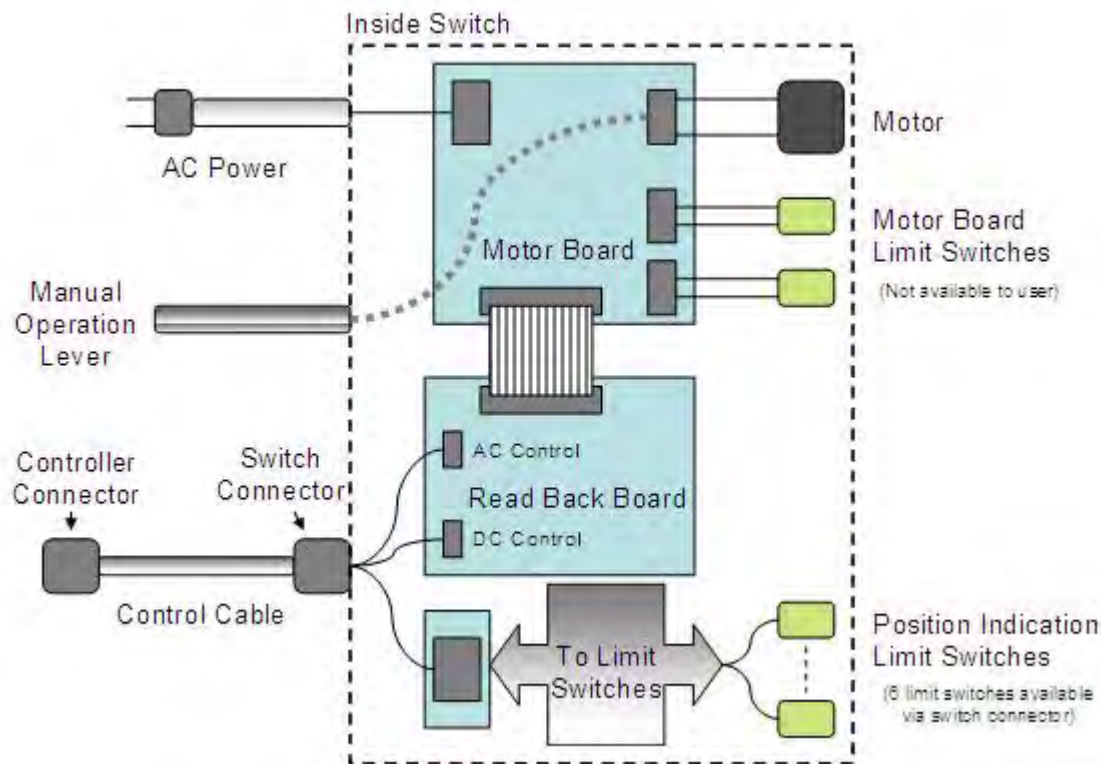

- Low insertion loss
- Low VSWR
- Motor drive switching
- Indoor applications
- Emergency manual operation
- Pressurized upon request
- Two-way switches

Specifications

Model Number	DC 60000-300	DC 60000-305
Input/Output Connectors	3-1/8" EIA	3-1/8" EIA
Impedance	50 ohms	50 ohms
Peak Voltage⁴ at Sea Level	6 kV	6 kV
Frequency Range¹	DC 900 MHz	DC 900 MHz
Max. Altitude²	10,000 feet (3,050 m)	10,000 feet (3,050 m)
Ambient Temperature	32°F (0°C) to 113°F (45°C)	32°F (0°C) to 113°F (45°C)
Storage Temperature	32°F (0°C) to 122°F (50°C)	32°F (0°C) to 122°F (50°C)
Storage/ Ambient Humidity³	0-98% non condensing	0-98% non condensing

Average Power⁴

108 MHz	≤ 40.5 kW	≤ 40.5 kW
230 MHz	≤ 28 kW	≤ 28 kW
776 MHz	≤ 15.1 kW	≤ 15.1 kW
860 MHz	≤ 14.4 kW	≤ 14.4 kW
Insertion Loss	≤ 0.1 dB	≤ 0.1 dB
VSWR	≤ 1.05	≤ 1.05
Isolation	> 60 dB	> 60 dB
Switching Time	3 sec.	3 sec.

Electrical Data

Motor Operating Voltage	115 V AC/50/60 Hz	230 V AC/50/60 Hz
Motor Operating Current	1.25 Amps-start 0.6 Amps-run	0.924 Amps-start 0.50 Amps-run
Control Voltage	12/24 V DC, 115/230 V AC	12/24 V DC, 115/230 V AC

Limit Switches Rating⁵

Voltage	125/230 V AC	125/230 V AC
Current	1/3HP, 10 Amps	1/3HP, 10 Amps
Weight	54 lbs (24.5 kg)	54 lbs (24.5 kg)

Notes

- 1) Special operating frequency requests beyond specified operating range accepted. Call factory for details.
- 2) For more than 5,000 feet (1,524 m), please consult the factory.
- 3) Coaxial switches must not to be exposed to condensing moisture environments.
- 4) 104°F (+40°C) ambient temperature, 145°F (63°C) outer temperature, 248°F (120°C) inner temperature, sea level, 0 PSIG, VSWR=1.0
- 5) Limit Switches are used for readout and position indication.

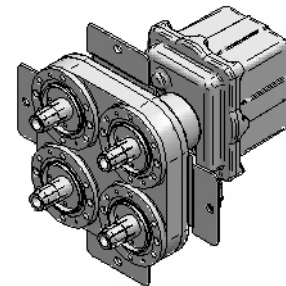
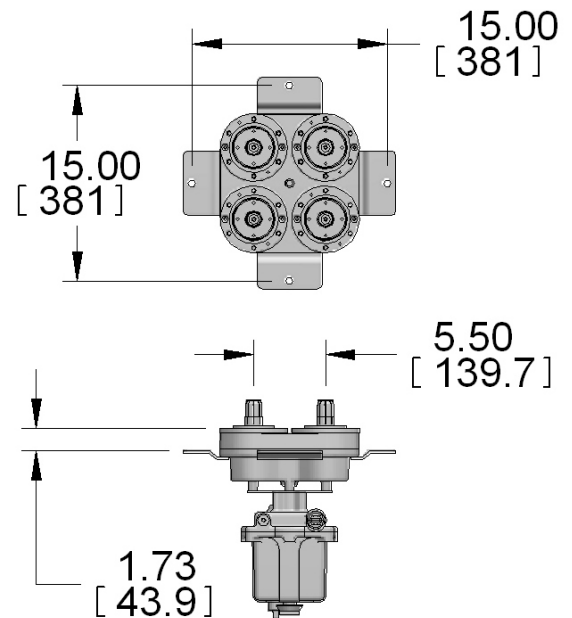

Control and Monitor Connector Pin Assignment Diagram

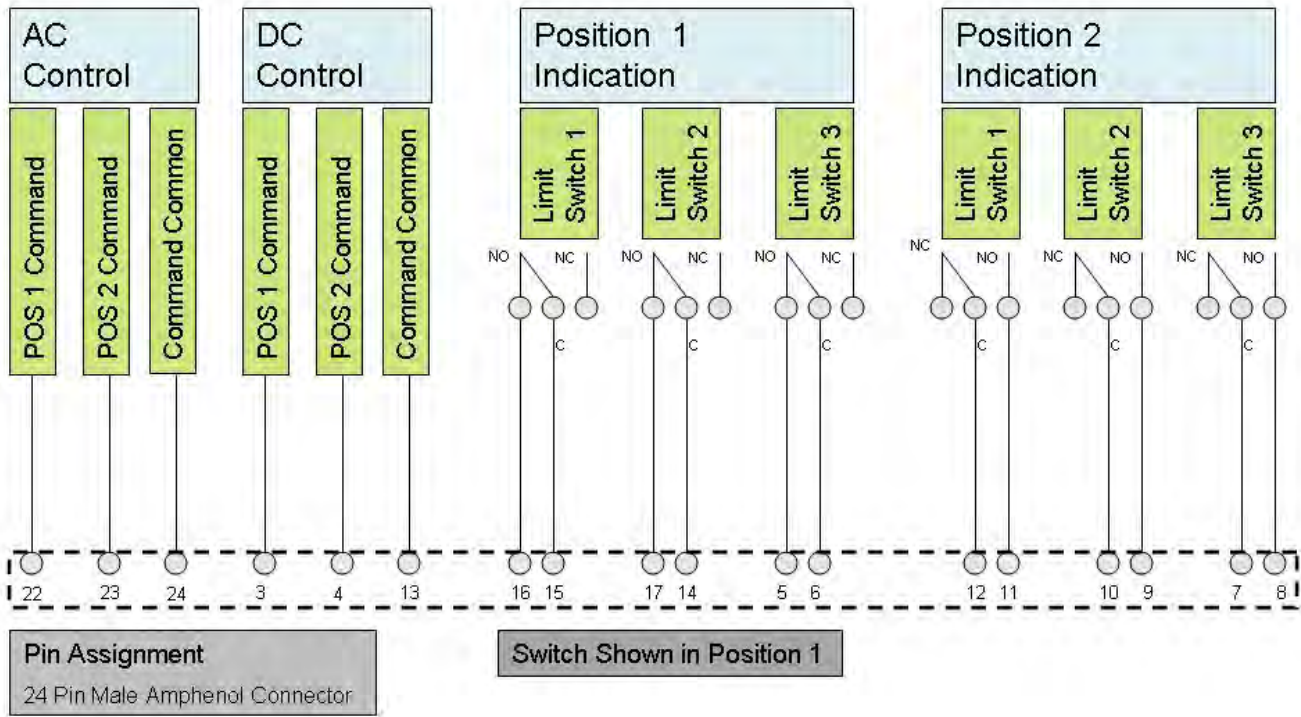

Electrical Block Diagram

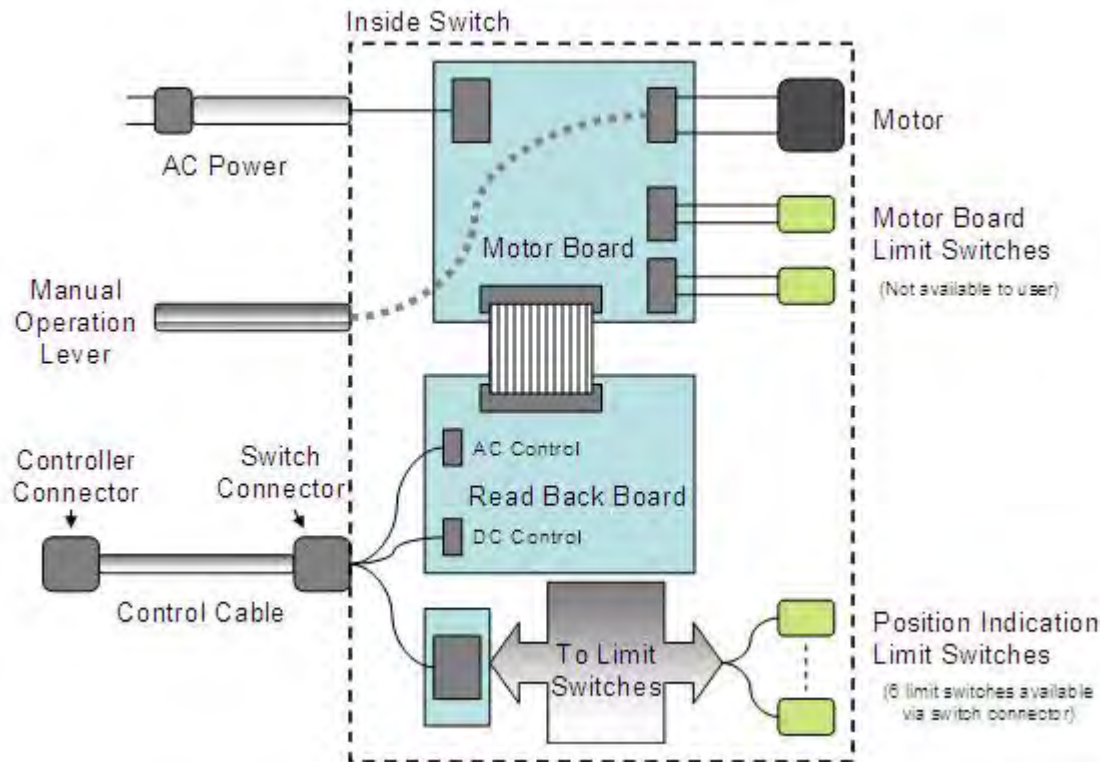

- Low insertion loss
- Low VSWR
- Motor drive switching
- Indoor applications
- Emergency manual operation
- Pressurized upon request
- Two-way switches

Specifications

Model Number	DC 60000-400	DC 60000-405
Input/output Connectors	4-1/16" Flanged	4-1/16" Flanged
Impedance	50 ohms	50 ohms
Peak Voltage⁴ at Sea Level	9 kV	9 kV
Frequency Range¹	DC 800 MHz	DC 800 MHz
Max. Altitude²	10,000 feet (3,050 m)	10,000 feet (3,050 m)
Ambient Temperature	32°F (0°C) to 113°F (45°C)	32°F (0°C) to 113°F (45°C)
Storage Temperature	32°F (0°C) to 122°F (50°C)	32°F (0°C) to 122°F (50°C)
Storage/ Ambient Humidity³	0-98% non condensing	0-98% non condensing

Average Power⁴

108 MHz	≤ 64.7 kW	≤ 64.7 kW
230 MHz	≤ 44.6 kW	≤ 44.6 kW
776 MHz	≤ 24.1 kW	≤ 24.1 kW
860 MHz	≤ 22.9 kW	≤ 22.9 kW
Insertion Loss	≤ 0.1 dB	≤ 0.1 dB
VSWR	≤ 1.05	≤ 1.05
Isolation	> 60 dB	> 60 dB
Switching Time	3 sec.	3 sec.

Electrical Data

Motor Operating Voltage	115 V AC/50/60 Hz	230 V AC/50/60 Hz
Motor Operating Current	1.25 Amps-start 0.6 Amps-run	0.924 Amps-start 0.50 Amps-run
Control Voltage	12/24 V DC, 115/230 V AC	12/24 V DC, 115/230 V AC

Limit Switches Rating⁵

Voltage	125/230 V AC	125/230 V AC
Current	1/3HP, 10 Amps	1/3HP, 10 Amps
Weight	78 lbs (35 kg)	78 lbs (35 kg)

Notes

- 1) Special operating frequency requests beyond specified operating range accepted. Call factory for details.
- 2) For more than 5,000 feet (1,524 m), please consult the factory.
- 3) Coaxial switches must not to be exposed to condensing moisture environments.
- 4) 104°F (+40°C) ambient temperature, 145°F (63°C) outer temperature, 248°F (120°C) inner temperature, sea level, 0 PSIG, VSWR=1.0
- 5) Limit Switches are used for readout and position indication.

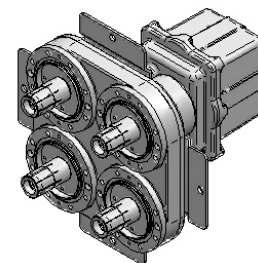
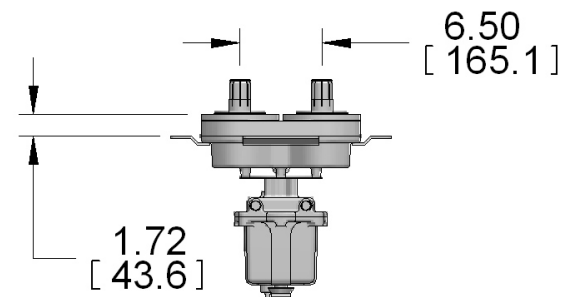
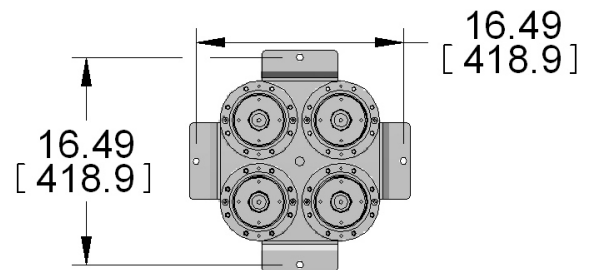

Control and Monitor Connector Pin Assignment Diagram

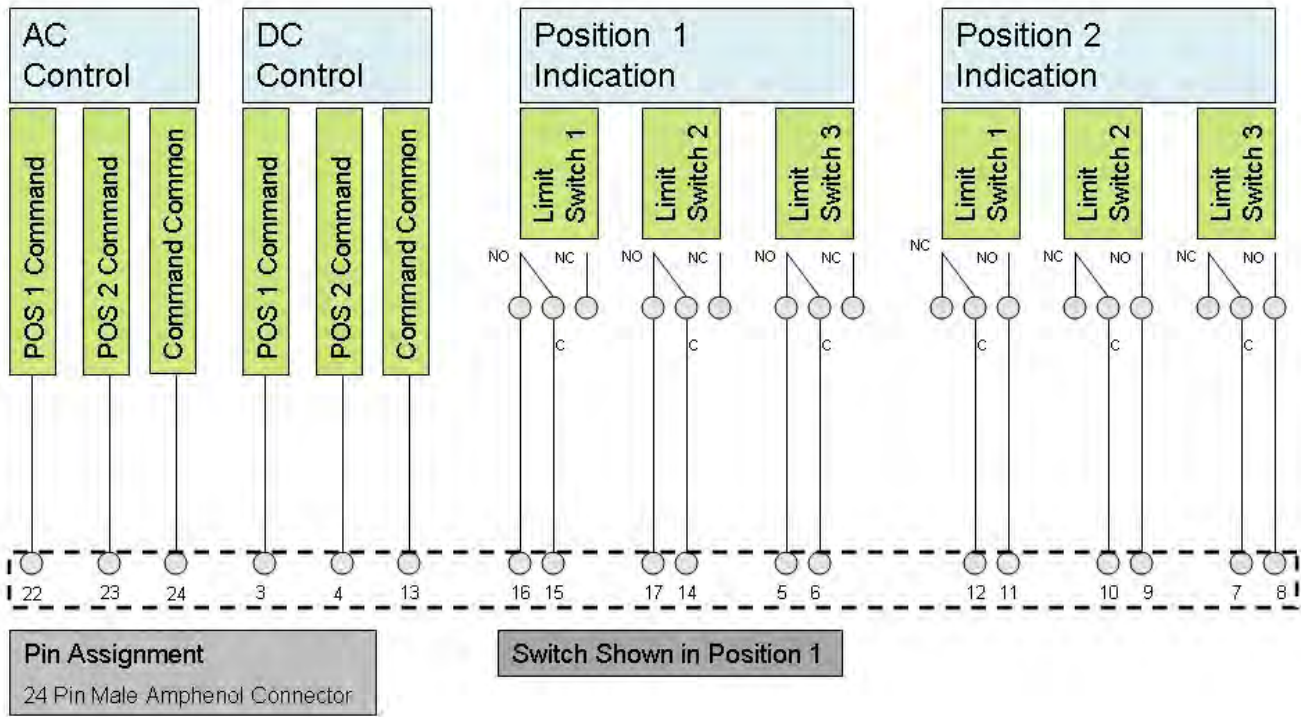

Electrical Block Diagram

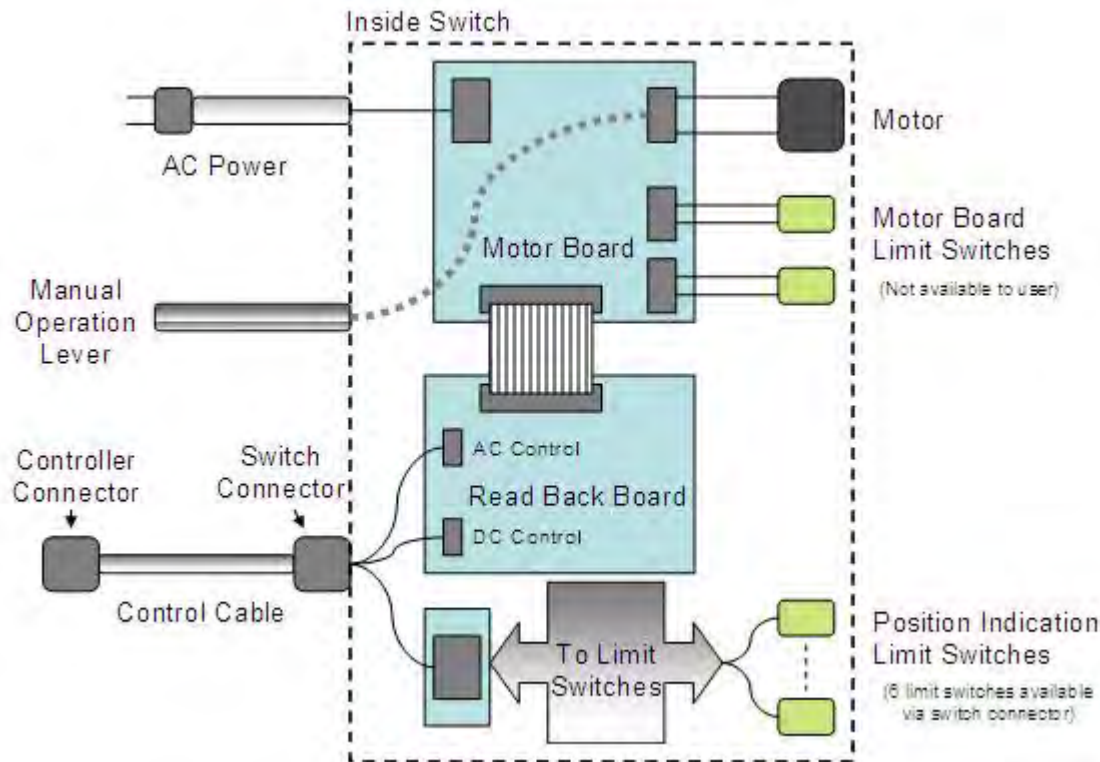

- Low insertion loss
- Low VSWR
- Motor drive switching
- Indoor applications
- Emergency manual operation
- Pressurized upon request
- Two-way switches

Specifications

Model Number	DC 60000-600	DC 60000-605
Input/output Connectors	6-1/8" EIA	6-1/8" EIA
Impedance	50 ohms	50 ohms
Peak Voltage⁴ at Sea Level	12 kV	12 kV
Frequency Range¹	DC 800 MHz	DC 800 MHz
Max. Altitude²	10,000 feet (3,050 m)	10,000 feet (3,050 m)
Ambient Temperature	32°F (0°C) to 113°F (45°C)	32°F (0°C) to 113°F (45°C)
Storage Temperature	32°F (0°C) to 122°F (50°C)	32°F (0°C) to 122°F (50°C)
Storage/ Ambient Humidity³	0-98% non condensing	0-98% non condensing

Average Power⁴

108 MHz	≤ 136.3 kW	≤ 136.3 kW
230 MHz	≤ 94.1 kW	≤ 94.1 kW
776 MHz	≤ 50.7 kW	≤ 50.7 kW
Insertion Loss	≤ 0.1 dB	≤ 0.1 dB
VSWR	≤ 1.05	≤ 1.05
Isolation	> 60 dB	> 60 dB
Switching Time	4 sec.	4 sec.

Electrical Data

Motor Operating Voltage	115 V AC/50/60 Hz	230 V AC/50/60 Hz
Motor Operating Current	1.25 Amps-start 0.6 Amps-run	0.924 Amps-start 0.5 Amps-run
Control Voltage	12/24 V DC, 115/230 V AC	12/24 V DC, 115/230 V AC

Limit Switches Rating⁵

Voltage	125/230 V AC	125/230 V AC
Current	1/3HP, 10 Amps	1/3HP, 10 Amps
Weight	170 lbs (77 kg)	170 lbs (77 kg)

Notes

- 1) Special operating frequency requests beyond specified operating range accepted. Call factory for details.
- 2) For more than 5,000 feet (1,524 m), please consult the factory.
- 3) Coaxial switches must not to be exposed to condensing moisture environments.
- 4) 104°F (+40°C) ambient temperature, 145°F (63°C) outer temperature, 248°F (120°C) inner temperature, sea level, 0 PSIG, VSWR=1.0
- 5) Limit Switches are used for readout and position indication.

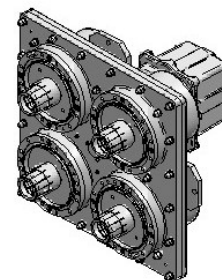
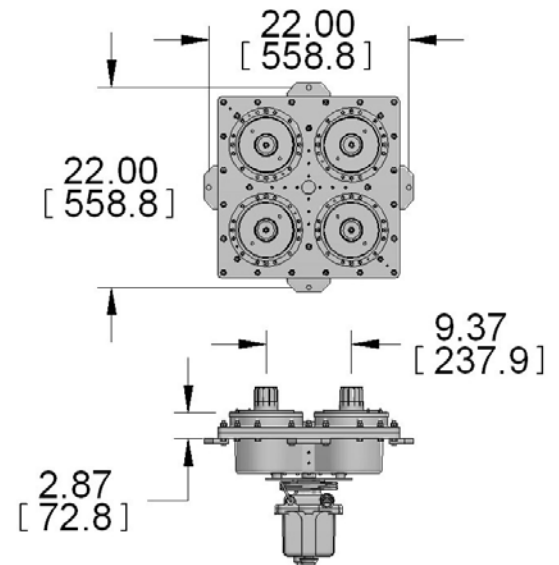

Control and Monitor Connector Pin Assignment Diagram

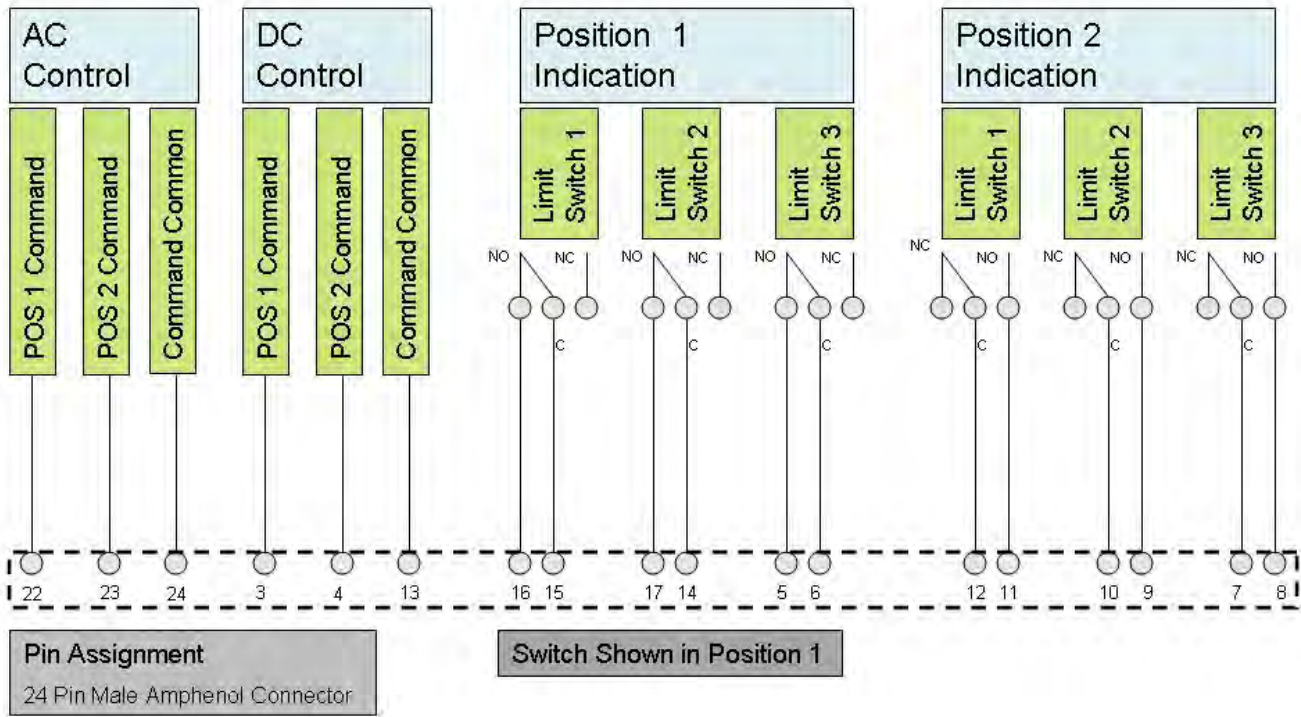

Electrical Block Diagram

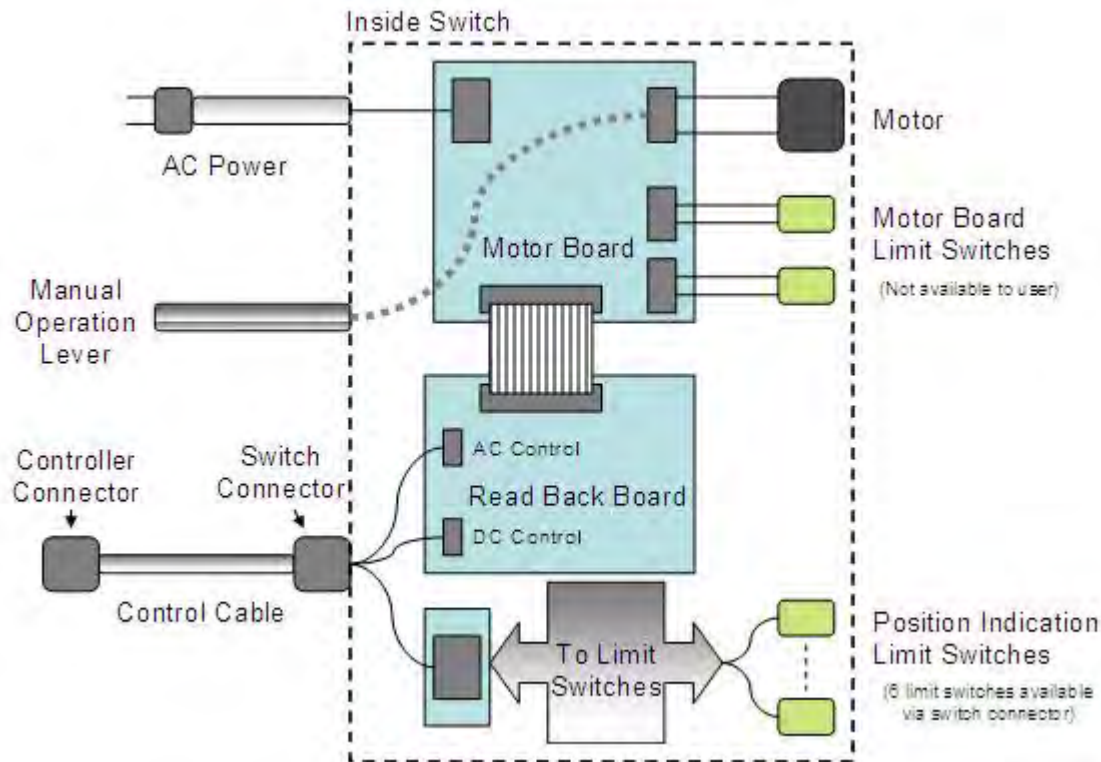

Dielectric Communications has been a major supplier of large high power waveguide to the microwave industry for the past two decades. This experience has resulted in design, manufacturing, and testing techniques that represent the current state-of-the art.

The High Power Alternative

Each form of transmission line has certain features which make its use more advantageous over other types of transmission systems. For UHF television applications, waveguide is particularly attractive because it out performs coaxial transmission line in virtually every area of importance. Waveguide can handle power levels far in excess of coaxial line ratings. Because there is no center conductor, waveguide is much less susceptible to shock and vibration during shipping and installation. No center conductor means no insulators and consequently lower loss.

Complete Systems

Dielectric's product line includes not only individual waveguide components and accessories, but integrated waveguide feed systems as well. Typical feed systems include such items as straight waveguide, sweeps and elbows, mitre bends, twists, switches, couplers, and other components as required for a specific application. In order to provide system compatibility, each component must be manufactured with stringent electrical and mechanical controls.

Quality Manufacturing

Extreme care is taken to ensure a superior surface finish on the flanges. Flange flatness tolerances do not exceed a total deviation over 5 to 10 mils on a flange face. Deviations exceeding these dimensional tolerances can result in serious arcing at the flange junction in a high power system. Another unique process welds the flanges in a manner that prevents localized distortion, thus minimizing the periodic VSWR spike that is often characteristic of transmission line systems. Facing the flanges, after welding, ensures accurate parallelism, thus minimizing interface discontinuities.

Precision Welding

Dielectric's waveguide is spayarc argon® welded by unique techniques using precision tooling and fixtures. These techniques eliminate distortion and bow by maintaining uniform stress loading and uniform weld penetration. Consequently, mechanical stability is attained and performance degradation of the guide with aging is eliminated. This is extremely important in long waveguide runs where low VSWR is necessary.

WR Line

Size	Frequency		
	470-494 MHz	494-680 MHz	650-880 MHz
WR 1800	Yes	N/A	N/A
WR 1500	N/A	Yes	N/A
WR 1150	N/A	N/A	Yes

Specifications are subject to change without notice.

- High power UHF applications
- Low insertion loss
- Low VSWR
- Outdoor/indoor applications
- Works in pressurized systems

Specifications

Impedance	50 ohms
Peak Voltage at Sea Level	225 kV
Peak Power at Sea Level	80 MW
Frequency Range	$470 \leq F \leq 494$ MHz
Ambient Temperature	-40°F (-40°C) to 122°F (50°C)
Ambient Humidity	0-98% non condensing
Storage Temperature	32°F (0°C) to 122°F (50°C)
Storage/Ambient Humidity	0-98% non condensing
Max. Altitude¹	10,000 feet (3,050 m)

Average Power²

473 MHz	≤ 1400 kW
485 MHz	≤ 1400 kW
491 MHz	≤ 1400 kW

Loss/100 feet²

473 MHz	0.046 dB
485 MHz	0.045 dB
491 MHz	0.044 dB

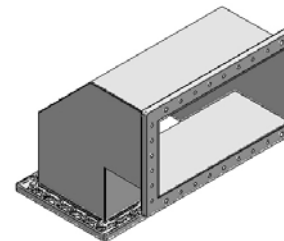
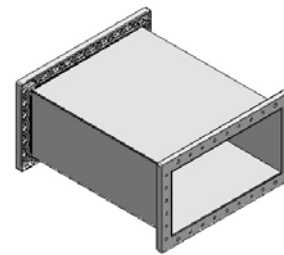

Notes

- 1) For more than 5,000 feet (1,524 m), please consult the factory.
- 2) 104°F (+40°C) ambient temperature, sea level, 0 PSIG, VSWR=1.0

Straight Line Section

Model Number	Weight (per foot)	VSWR 470-494 MHz
DC 50013-10	12 lbs (5.44 kg)	< 1.03

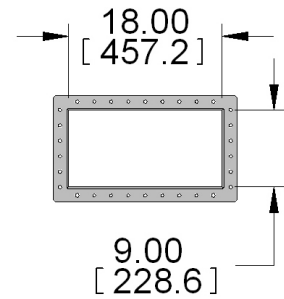
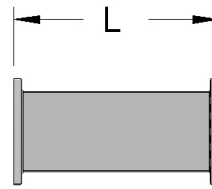

90° "E" Mitre Elbow

Model Number	Weight	VSWR 470-494 MHz
DC 50013-6	19 lbs (8.6 kg)	< 1.03

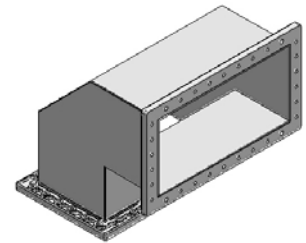
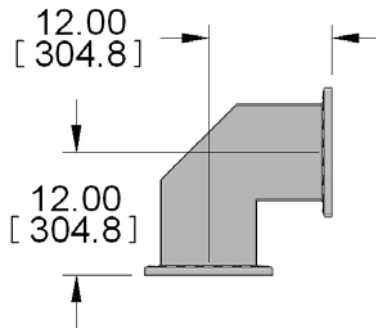

90° "H" Mitre Elbow

Model Number	Weight	VSWR 470-494 MHz
DC 50013-5	24 lbs (11 kg)	< 1.03

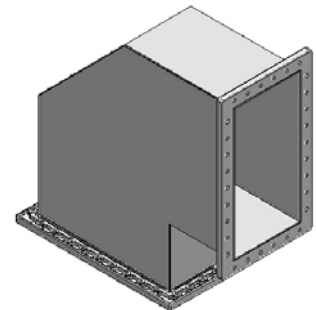
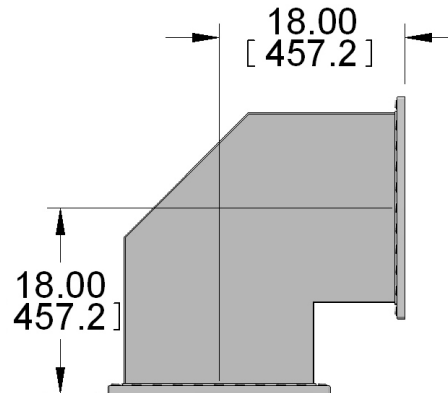

- High power UHF applications
- Low insertion loss
- Low VSWR
- Outdoor/indoor applications
- Works in pressurized systems

Specifications

Impedance	50 ohms
Peak Voltage at Sea Level	187 kV
Peak Power at Sea Level	55 MW
Frequency Range	$494 \leq F \leq 680$ MHz
Ambient Temperature	-40°F (-40°C) to 122°F (50°C)
Ambient Humidity	0-98% non condensing
Storage Temperature	32°F (0°C) to 122°F (50°C)
Storage/Ambient Humidity	0-98% non condensing
Max. Altitude¹	10,000 feet (3,050 m)

Average Power²

509 MHz	≤ 1300 kW
569 MHz	≤ 975 kW
629 MHz	≤ 650 kW

Loss/100 feet²

509 MHz	0.070 dB
569 MHz	0.060 dB
629 MHz	0.055 dB

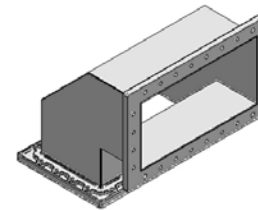
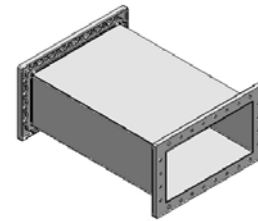

Notes

- 1) For more than 5,000 feet (1,524 m), please consult the factory.
- 2) 104°F (+40°C) ambient temperature, sea level, 0 PSIG, VSWR=1.0

Straight Line Section

Model Number	Weight (per foot)	VSWR 494-680 MHz
DC 50014-10	7 lbs (3.18 kg)	< 1.03

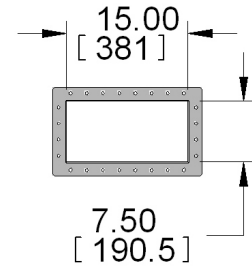
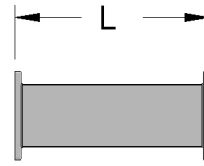

90° "E" Mitre Elbow

Model Number	Weight	VSWR 494-680 MHz
DC 50014-6	18 lbs (8.2 kg)	< 1.03

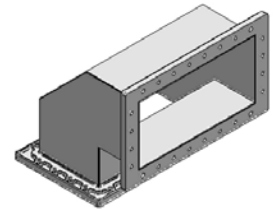
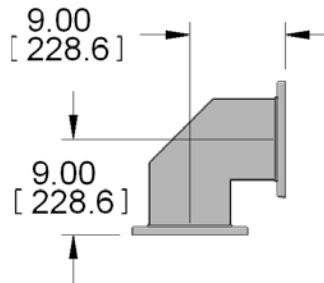

90° "H" Mitre Elbow

Model Number	Weight	VSWR 494-680 MHz
DC 50014-5	21 lbs (9.5 kg)	< 1.03

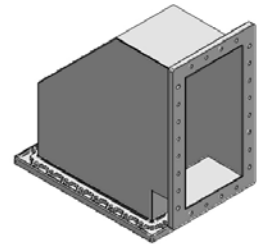
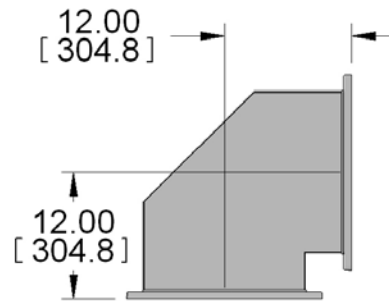

- High power UHF applications
- Low insertion loss
- Low VSWR
- Outdoor/indoor applications
- Works in pressurized systems

Specifications

Impedance	50 ohms
Peak Voltage at Sea Level	144 kV
Peak Power at Sea Level	35 MW
Frequency Range	$650 \leq F \leq 880$ GHz
Ambient Temperature	-40°F (-40°C) to 122°F (50°C)
Ambient Humidity	0-98% non condensing
Storage Temperature	32°F (0°C) to 122°F (50°C)
Storage/Ambient Humidity	0-98% non condensing
Max. Altitude¹	10,000 feet (3,050 m)

Average Power²

653 MHz	≤ 650 kW
731 MHz	≤ 300 kW
803 MHz	≤ 340 kW

Loss/100 feet²

653 MHz	0.108 dB
731 MHz	0.090 dB
803 MHz	0.083 dB

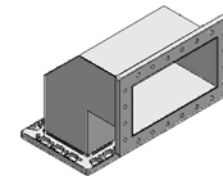
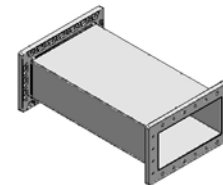

Notes

- 1) For more than 5,000 feet (1,524 m), please consult the factory.
- 2) 104°F (+40°C) ambient temperature, sea level, 0 PSIG, VSWR=1.0

Straight Line Section

Model Number	Weight (per foot)	VSWR 650-806 MHz
DC 50015-10	5 lbs (2.27 kg)	< 1.03

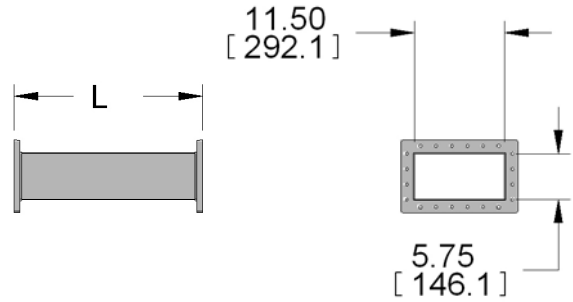

90° "E" Mitre Elbow

Model Number	Weight	VSWR 650-806 MHz
DC 50015-6	16 lbs (7.3 kg)	< 1.03

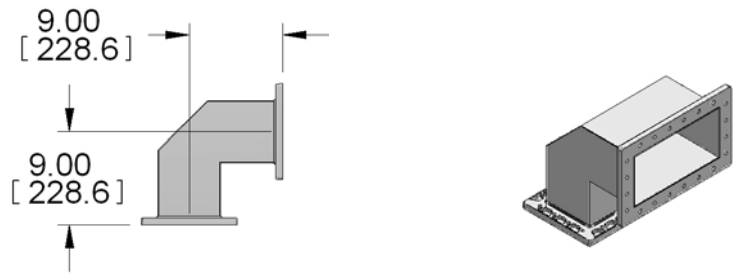

90° "H" Mitre Elbow

Model Number	Weight	VSWR 650-806 MHz
DC 50015-5	18 lbs (8.2 kg)	< 1.03

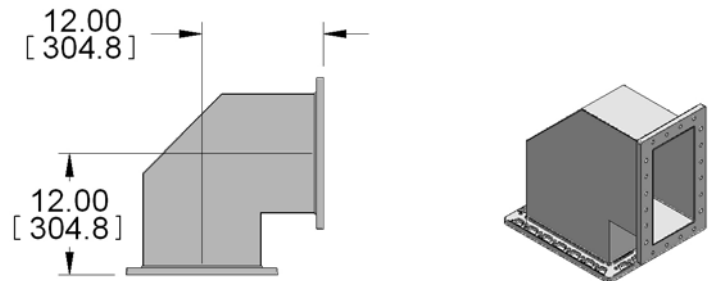

Leading the broadcast industry for over a half century.

Founded in 1942, Dielectric continues to be at the forefront of RF component design and manufacture. Whether the transmission format is analog or digital, Dielectric's conservative design philosophy will ensure the highest quality and most reliable products are available to you, our customer.

Quality components keep you on the air.

For the broadcaster, every second off the air is lost revenue. Therefore, each component in your broadcast system must be of the highest quality available. Dielectric's reputation for engineering excellence is recognized throughout the world. When emergency parts or services are needed, you can count on Dielectric to provide assistance and help to get you back on the air.

Features

- Are used for switch or break transmitter's paths in single, half, back-up, etc.
- Also used to automatically patch the transmitter's output to dummy load, between main and standby antennas, bypassing intermediate RF systems (combiners, splitters, etc.)
- The switch is accomplished using a motor drive. Manual option is also available which is especially useful in emergency situations.
- WR Switches may be mounted in any position
- Simple setup and maintenance

4-Port Motorized Switches

Size	Frequency			Motor Drive
	470-494 MHz	494-680 MHz	650-880 MHz	
WR 1800	Yes	N/A	N/A	115/230 V AC, 60/50 Hz
WR 1500	N/A	Yes	N/A	115/230 V AC, 60/50 Hz
WR 1150	N/A	N/A	Yes	115/230 V AC, 60/50 Hz

Specifications are subject to change without notice.

- High power UHF applications
- Low insertion loss
- Low VSWR
- Motor drive switching
- Indoor applications
- Emergency manual operation
- Mechanical switch position indicator
- High isolation
- H-plane switch
- E-plane switch

Specifications

Model Number	A50013-33	A50013-34	A50013-35
Input/Output Connectors	WR 1800	WR 1800	WR 1800
Impedance	50 ohms	50 ohms	50 ohms
Peak Power at Sea Level	124 MW	124 MW	124 MW
Frequency Range	470 ≤ F ≤ 494 MHz	470 ≤ F ≤ 494 MHz	470 ≤ F ≤ 494 MHz
Max. Altitude¹	10,000 feet (3,050 m)	10,000 feet (3,050 m)	10,000 feet (3,050 m)
Ambient Temperature	59°F to 104°F (15°C to 40°C)	59°F to 104°F (15°C to 40°C)	59°F to 104°F (15°C to 40°C)
Storage Temperature	32°F to 122°F (0°C to 50°C)	32°F to 122°F (0°C to 50°C)	32°F to 122°F (0°C to 50°C)
Storage/ Ambient Humidity²	0-98% non-condensing	0-98% non-condensing	0-98% non-condensing

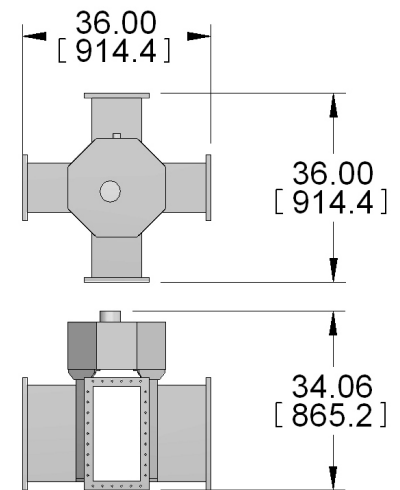

Average Power³

494 MHz	≤ 300 kW	≤ 300 kW	≤ 300 kW
Insertion Loss	≤ 0.02 dB	≤ 0.02 dB	≤ 0.02 dB
VSWR	≤ 1.03	≤ 1.03	≤ 1.03
Isolation	> 70 dB	> 70 dB	> 70 dB
Switching Time	6 sec.	6 sec.	6 sec.

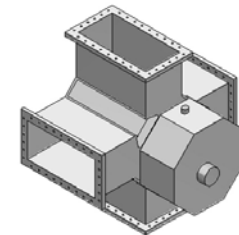

Electrical Data

Motor Operating Voltage	115 V AC 60 Hz	115 V AC 60 Hz	230 V AC 50/60 Hz
Motor Operating Current	1.4 Amps-start 1.4 Amps-run	1.4 Amps-start 1.4 Amps-run	Contact Factory
Control Voltage	12 V DC	24 V DC	12/24 V DC

Limit Switch Rating⁴

Voltage	277 V AC 28 V DC	120 V AC	Contact Factory
Current	16 Amps	10 Amps	Contact Factory
Weight	299 lbs (135.6 kg)	299 lbs (135.6 kg)	Contact Factory

Notes

- 1) For more than 5,000FT (1,524M), please consult the factory.
- 2) WR switches must not be exposed to condensing moisture environments.
- 3) 104°F (+40°C) ambient temperature, sea level, 0 PSIG, VSWR=1.0
- 4) Limit switches are used for readout and position indication

Control and Monitor Connector Pin Assignment Diagram

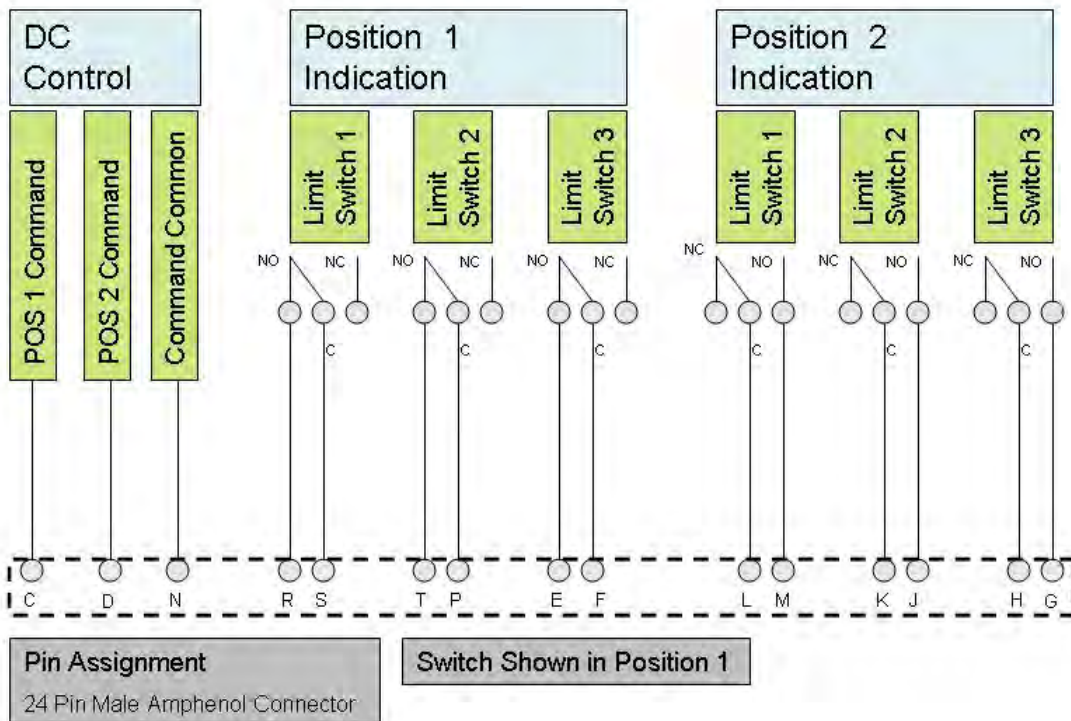

Electrical Block Diagram

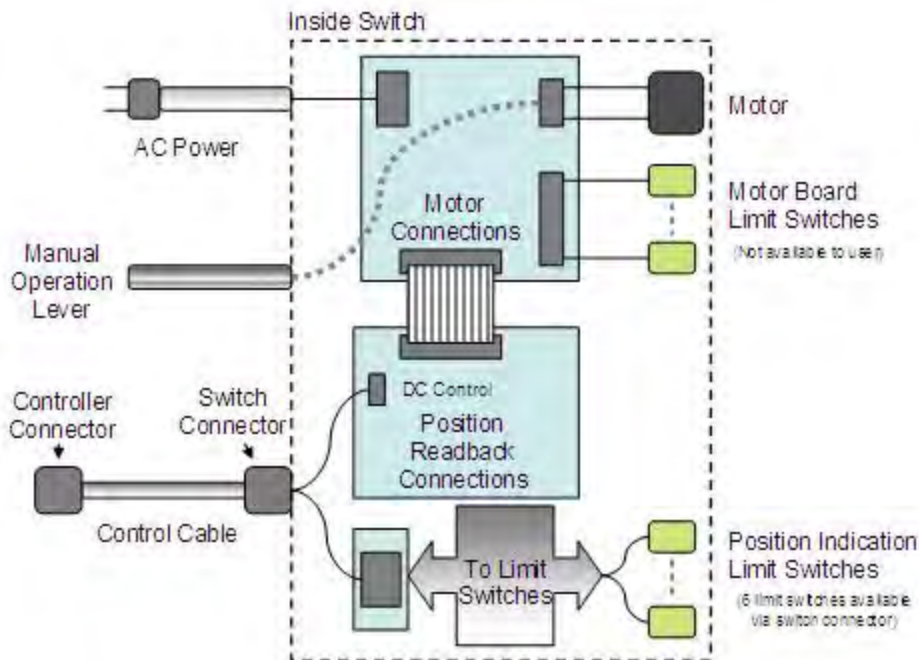

- High power UHF applications
- Low insertion loss
- Low VSWR
- Motor drive switching
- Indoor applications
- Emergency manual operation
- Mechanical switch position indicator
- High isolation
- H-plane switch

Specifications

Model Number	B50014-33	B50014-34
Input/Output Connectors	WR 1500	WR 1500
Impedance	50 ohms	50 ohms
Peak Power at Sea Level	86 MW	86 MW
Frequency Range	494 ≤ F ≤ 680 MHz	494 ≤ F ≤ 680 MHz
Max. Altitude¹	10,000 feet (3,050 m)	10,000 feet (3,050 m)
Ambient Temperature	59°F to 104°F (15°C to 40°C)	59°F to 104°F (15°C to 40°C)
Storage Temperature	32°F to 122°F (0°C to 50°C)	32°F to 122°F (0°C to 50°C)
Storage/ Ambient Humidity²	0-98% non-condensing	0-98% non-condensing

Average Power³

650 MHz	≤ 300 kW	≤ 300 kW
Insertion Loss	≤ 0.02 dB	≤ 0.02 dB
VSWR	≤ 1.03	≤ 1.03
Isolation	> 70 dB	> 70 dB
Switching Time	6 sec.	6 sec.

Electrical Data

Motor Operating Voltage	115 V AC 50/60 Hz	230 V AC 50/60 Hz
Motor Operating Current	1.25 Amps-start 0.6 Amps-run	0.93 Amps-start 0.5 Amps-run
Control Voltage	12/24 V DC 115/230 V AC	12/24 V DC 115/230 V AC

Limit Switch Rating⁴

Voltage	277 V AC 28 V DC	120 V AC 28 V DC
Current	113 HP / 10 Amps	113 HP / 10 Amps
Weight	197 lbs (89 kg)	197 lbs (89 kg)

Notes

- 1) For more than 5,000FT (1,524M), please consult the factory.
- 2) WR switches must not be exposed to condensing moisture environments.
- 3) 104°F (+40°C) ambient temperature, sea level, 0 PSIG, VSWR=1.0
- 4) Limit switches are used for readout and position indication

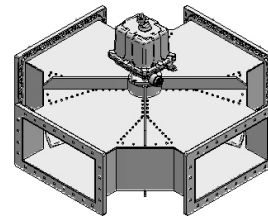
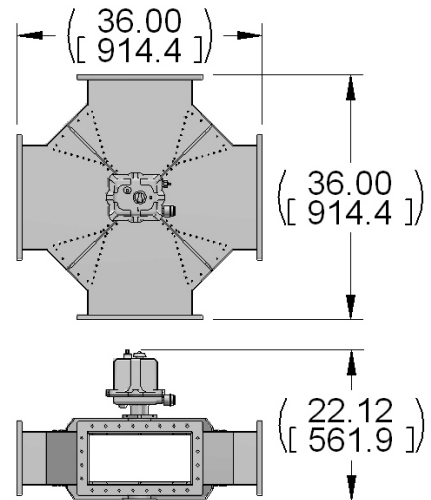

Control and Monitor Connector Pin Assignment Diagram

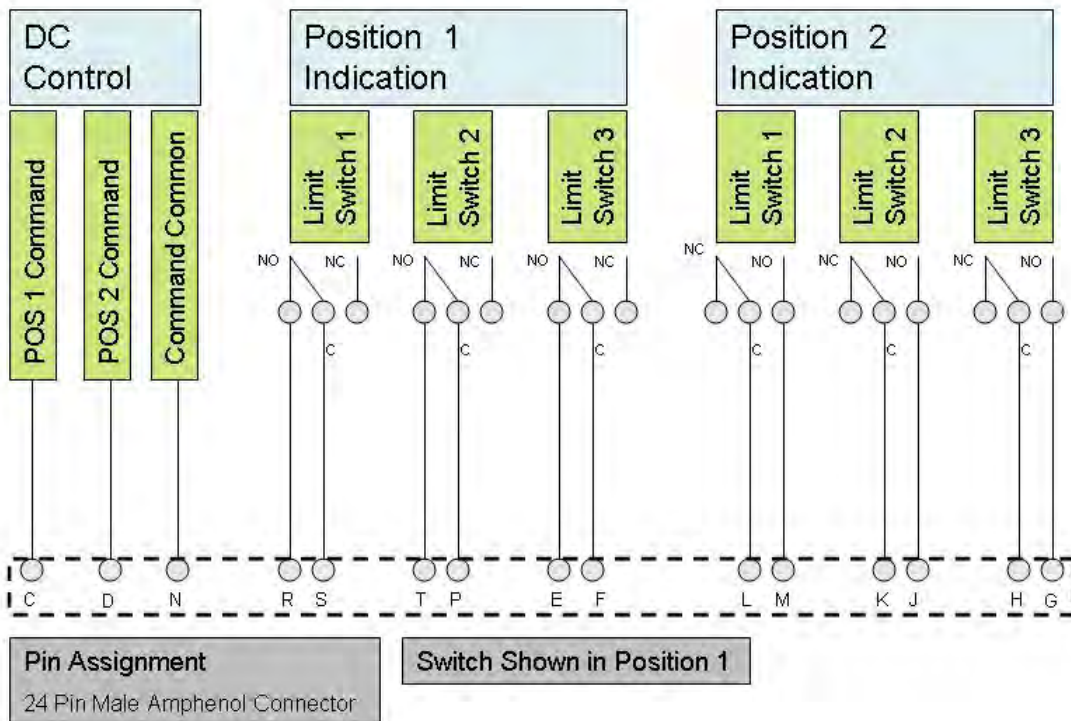

Electrical Block Diagram

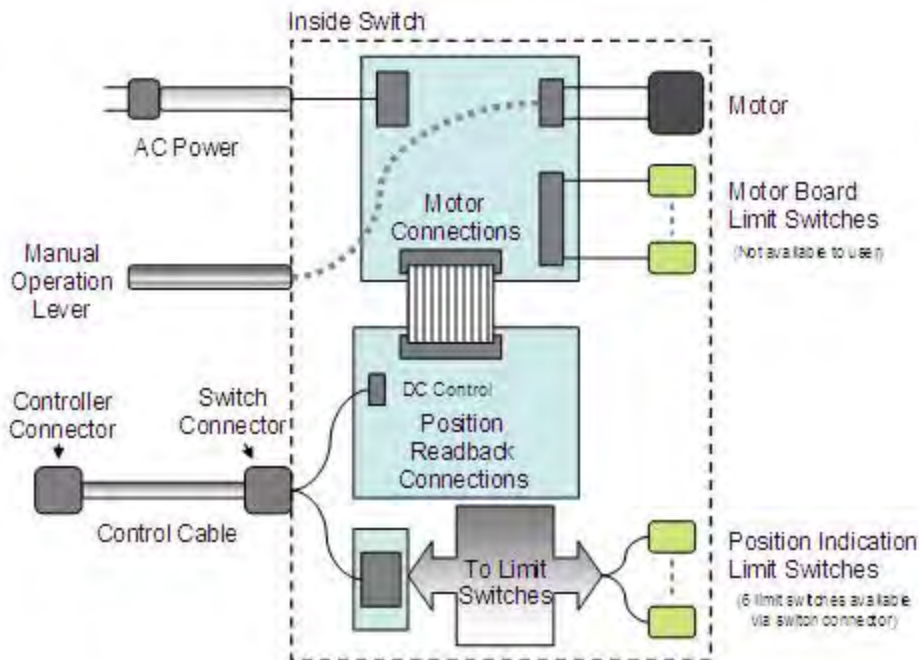

- High power UHF applications
- Low insertion loss
- Low VSWR
- Motor drive switching
- Indoor applications
- Emergency manual operation
- Mechanical switch position indicator
- High isolation
- H-plane switch

Specifications

Model Number	A50015-33	A50015-34	A50015-35
Input/Output Connectors	WR 1150	WR 1150	WR 1150
Impedance	50 ohms	50 ohms	50 ohms
Peak Power at Sea Level	50 MW	50 MW	50 MW
Frequency Range	650 ≤ F ≤ 880 MHz	650 ≤ F ≤ 880 MHz	650 ≤ F ≤ 880 MHz
Max. Altitude¹	10,000 feet (3,050 m)	10,000 feet (3,050 m)	10,000 feet (3,050 m)
Ambient Temperature	59°F to 104°F (15°C to 40°C)	59°F to 104°F (15°C to 40°C)	59°F to 104°F (15°C to 40°C)
Storage Temperature	32°F to 122°F (0°C to 50°C)	32°F to 122°F (0°C to 50°C)	32°F to 122°F (0°C to 50°C)
Storage/ Ambient Humidity²	0-98% non-condensing	0-98% non-condensing	0-98% non-condensing

Average Power³

806 MHz	≤ 300 kW	≤ 300 kW	≤ 300 kW
----------------	----------	----------	----------

Insertion Loss	≤ 0.02 dB	≤ 0.02 dB	≤ 0.02 dB
VSWR	≤ 1.03	≤ 1.03	≤ 1.03
Isolation	> 70 dB	> 70 dB	> 70 dB
Switching Time	6 sec.	6 sec.	6 sec.

Electrical Data

Motor Operating Voltage	115 V AC 60 Hz	115 V AC 60 Hz	230 V AC 50/60 Hz
Motor Operating Current	1.4 Amps-start 1.4 Amps-run	1.4 Amps-start 1.4 Amps-run	Contact Factory
Control Voltage	12 V DC	24 V DC	12/24 V DC

Limit Switch Rating⁴

Voltage	277 V AC 28 V DC	120 V AC	Contact Factory
Current	16 Amps	10 Amps	Contact Factory
Weight	134 lbs (61 kg)	134 lbs (61 kg)	Contact Factory

Notes

- 1) For more than 5,000FT (1,524M), please consult the factory.
- 2) WR switches must not be exposed to condensing moisture environments.
- 3) 104°F (+40°C) ambient temperature, sea level, 0 PSIG, VSWR=1.0
- 4) Limit switches are used for readout and position indication

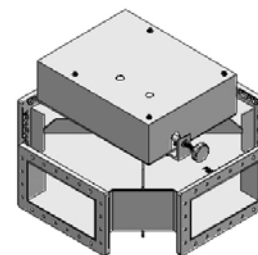
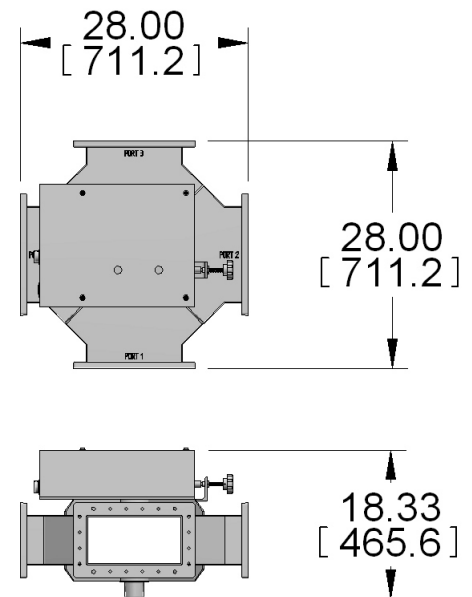

Control and Monitor Connector Pin Assignment Diagram

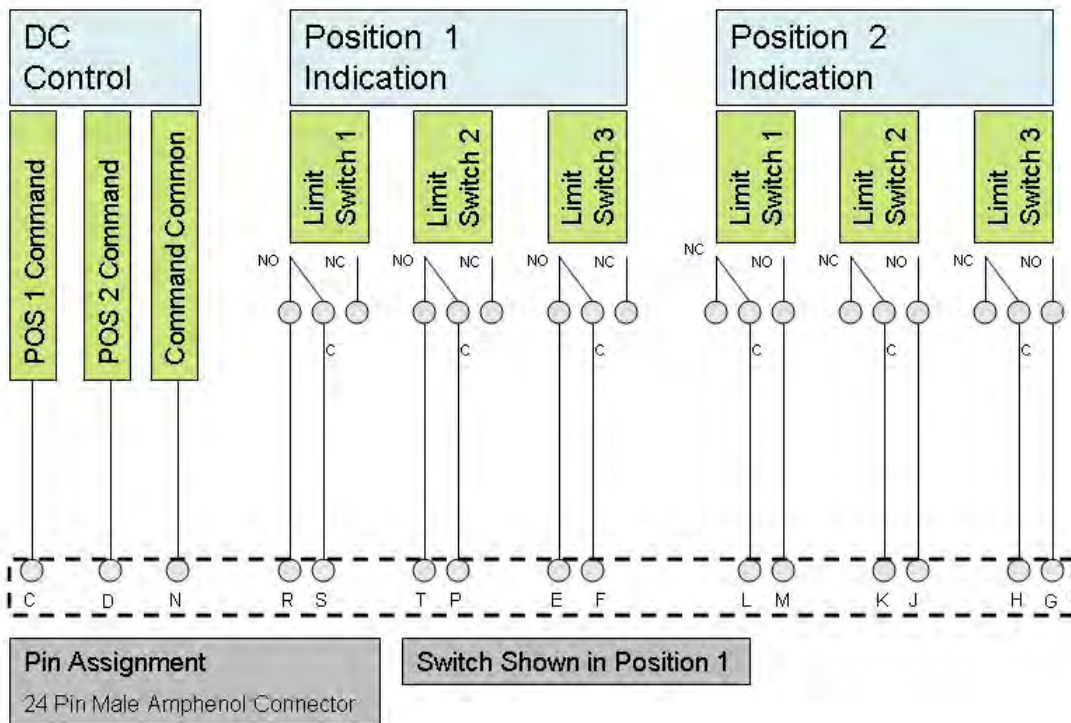

Electrical Block Diagram

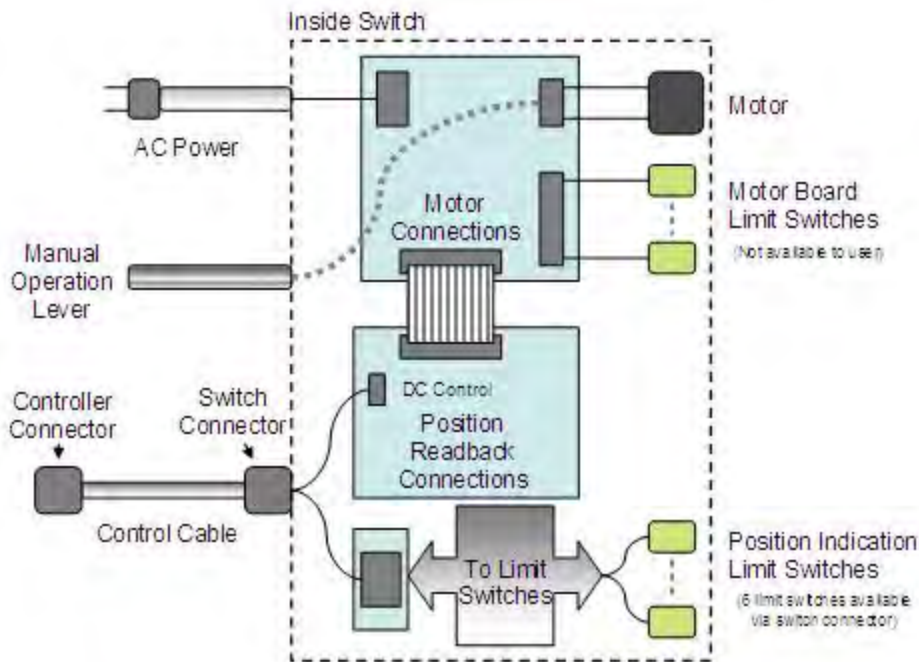

The unit is fully self-contained and housed in a 3.5 inch rack mounted chassis. The unit provides either local or remote control of two RF switched. The controller design uses a Programmable Logic Controller (PLC) to sense the inputs from the RF switch and produces the required timing and output commands to the RF switch. The relay control voltage for the RF switch is selectable on the rear of the Dual Switch Controller. Multi-mode of operation can be selected from touch panel interface. When LOCAL is selected, the RF switches can only be electrically controlled from the panel. When REMOTE is selected, the RF switched can only be electrically controlled remotely, or from web interface. When in LOCKOUT mode there is no electrical control.

Features

- Local and remote control and monitoring
- Easy to use, touch screen local interface
- Remote web control
- Normally closed transmitter interlock connection
- Custom setting for transmitter interlock delay
- Dual built-in control voltage selection (12 V DC or 24 V DC)

4-Port Motorized Controller

Item	AC Power	Contr. Relay Voltage
Dual Universal Controller	120-240 V AC, 50/60 Hz	12/24 V DC

Specifications are subject to change without notice.

- Allows control of one or two 2-ways switches (coaxial or WR)
- Local, remote or lockout operation
- Adjustable delay in switching
- 12 V DC or 24 V DC voltage control relay selection

Specifications

Model Number	DSC2
Part Number	11000010590
Dimensions (H x W x D)	5.25" x 19" x 8" (133.3 mm x 482.6 mm x 203 mm)
AC Power Requirements	110-240 V AC/50-60 Hz
AC Power Consumption (Controller only)	40 W



Loading of Remote Control Contacts

Operating Voltage	≤ 24 V DC
Operating Current	< 0.5 Amps

Loading of interlock contacts

Operating voltage	<=30V DC or <=250V AC
Operating current	<=3A

Control Relay Voltage	12 V DC, 24 V AC
Ambient Temperature	32°F (0°C) to 122°F (50°C)
Storage Temperature	-4°F (-20°C) to 158°F (70°C)
Storage/Ambient Humidity	0-90% non condensing
Weight (with U-link)	12.5 lbs (5.7 kg)

Notes

For custom controllers, please contact the factory.

Dual Switch Controller Input-Output Connections

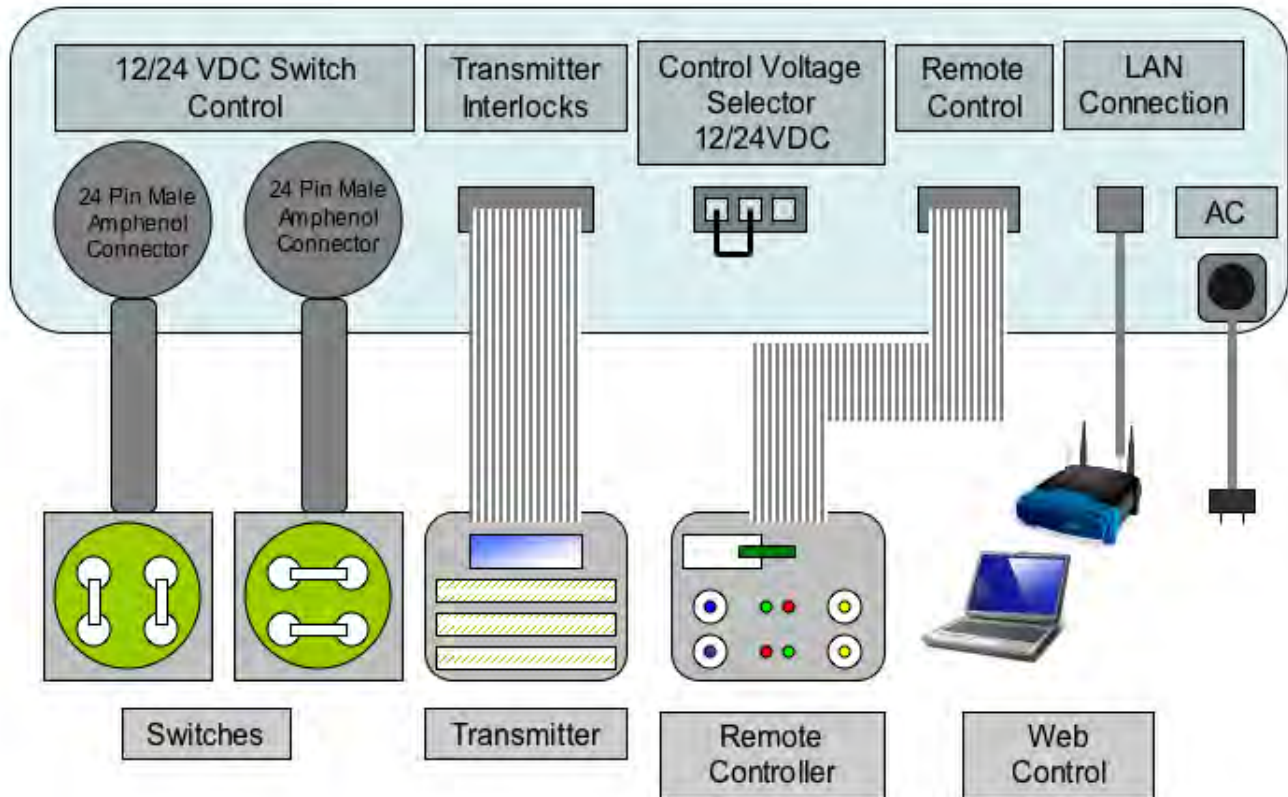

Notes

For custom controllers, please contact the factory.

Dual Switch Controller Block Diagram

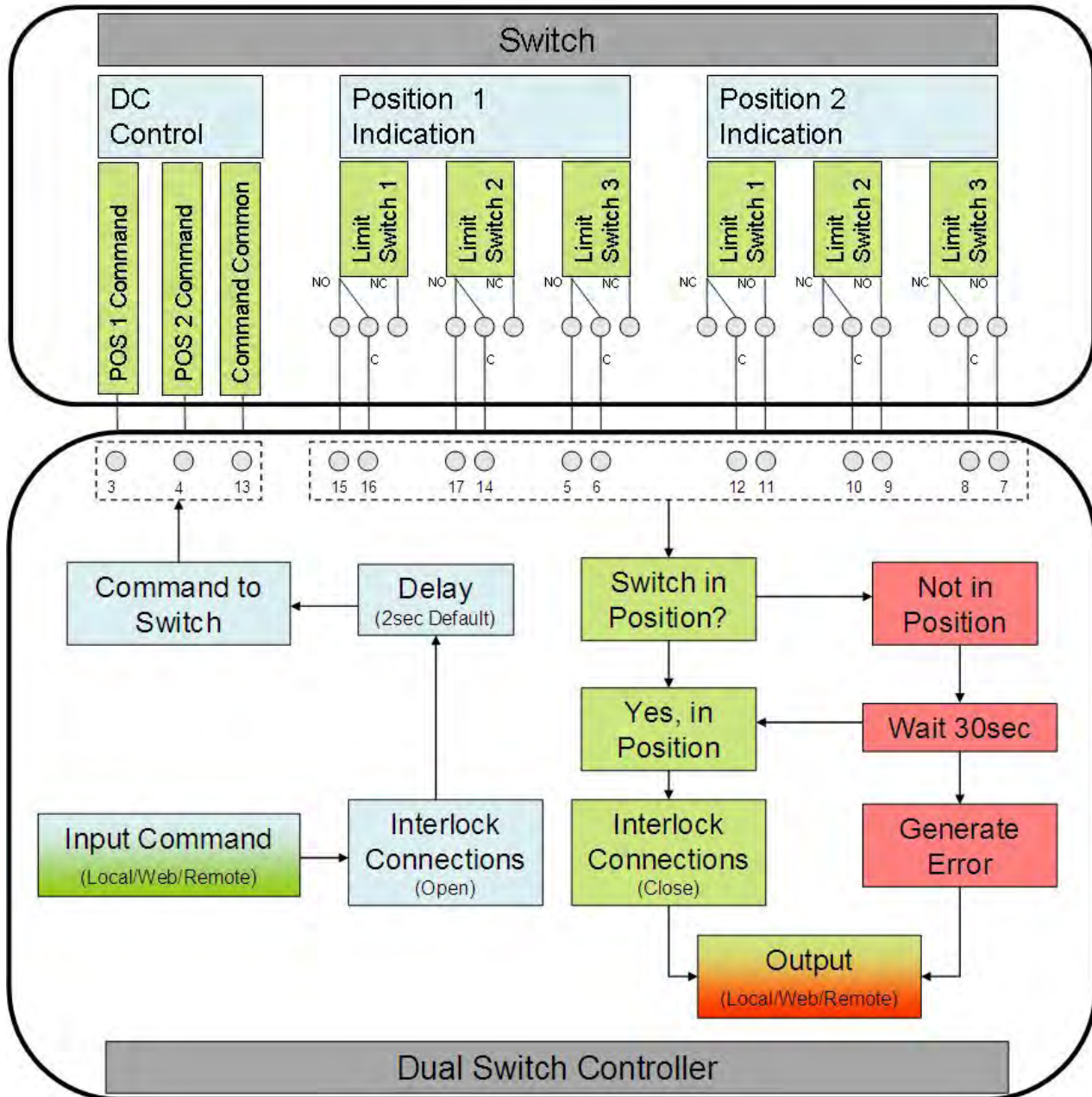

Notes

- 1) Switch-dual switch controller interface: 24 pin male amphenol connector.
- 2) Pins 5/6 and 11/12 are used inside the dual switch controller for switch position indication and are not routed to the interlock connections. Pins 15/16, 14/17, 9/10 and 7/8 are routed through the PLC to the interlock connections.
- 3) For custom controllers, please contact the factory.

- A comprehensive offer to facilitate measuring and maintenance work
- Offer tuning lines for improving VSWR directional couplers for measuring FWD and RFL power
- Adapters for different sizes of international connector systems

Standard Tuning Elements

Item	Page
UHF Coaxial Straight Line Tuning	133
Tunable UHF Elbow	134
UHF Waveguide (WR) Straight Line Tuning	135

Standard Directional Couplers/Probes

Item	Page
Standard Coaxial Directional Coupler with 1 or 4 Probes	136-137
Standard Waveguide Directional Coupler with 1 or 4 Probes	138-139

Standard Adapter/Reducers

Item	Page
Standard Coaxial Flanged Reducers	140
Standard WR 1800 to Coaxial Transitions	141
Standard WR 1500 to Coaxial Transitions	142
Standard WR 1150 to Coaxial Transitions	143

Standard Loads

Item	Page
Coaxial Water Column Load	144
Waveguide (WR) Water Column Load	145

Specifications are subject to change without notice.

- Used to improve VSWR
- Indoor applications
- Available with 4 tuning screws

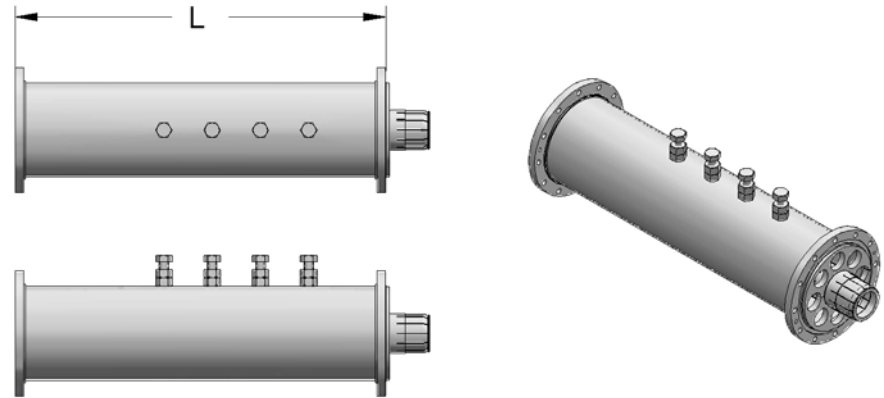

Specifications

Model Number	TUC1-4	TUC3-4	TUC4-4	TUC6-4
Input/output Connectors	1-5/8" EIA	3-1/8" EIA	4-1/16" FLG	6-1/8" EIA
Impedance	50 ohms	50 ohms	50 ohms	50 ohms
Outer Conductor	Aluminum	Aluminum	Aluminum	Aluminum
Tuning Screws	4	4	4	4

Frequency Range	470-860 MHz	470-860 MHz	470-860 MHz	470-776 MHz
Peak Voltage at Sea Level¹	4 kV	7.8 kV	11 kV	15.6 kV
Average Power²	≤ 5.4 kW	≤ 18 kW	≤ 28.7 kW	≤ 63.4 kW
Max. Altitude³	10,000 feet (3,050 m)	10,000 feet (3,050 m)	10,000 feet (3,050 m)	10,000 feet (3,050 m)
Ambient Temperature	32°F (0°C) to 113°F (45°C)	32°F (0°C) to 113°F (45°C)	32°F (0°C) to 113°F (45°C)	32°F (0°C) to 113°F (45°C)
Storage Temperature	32°F (0°C) to 122°F (50°C)	32°F (0°C) to 122°F (50°C)	32°F (0°C) to 122°F (50°C)	32°F (0°C) to 122°F (50°C)
Storage/Ambient Humidity	0-98%, non condensing	0-98%, non condensing	0-98%, non condensing	0-98%, non condensing
Length	15.00" (381 mm)	15.00" (381.0 mm)	20.5" (521 mm)	24" (610 mm)
Weight	2.6 lbs (1.2 kg)	5.0 lbs (2.3 kg)	9.0 lbs (4 kg)	13 lbs (6 kg)

Notes

- 1) Refers to 860 MHz and at maximum capacitive load (with screws full screw in).
- 2) 860 MHz (766 MHz-6-1/8" EIA), 104°F (+40°C) ambient temperature, 145°F (63°C) outer temperature, 248°F (120°C) inner temperature sea level, 0 PSIG, VSWR=1.0
- 3) For more than 5,000 feet (1,524 m), please consult the factory.
- 4) Copper outers and voltage probes and/or directional couplers as part of the body of the tuning sections, are available upon request.

Dielectric® Standard Tunable UHF Elbow

- Used to improve VSWR
- Indoor applications
- Available with 4 tuning screws

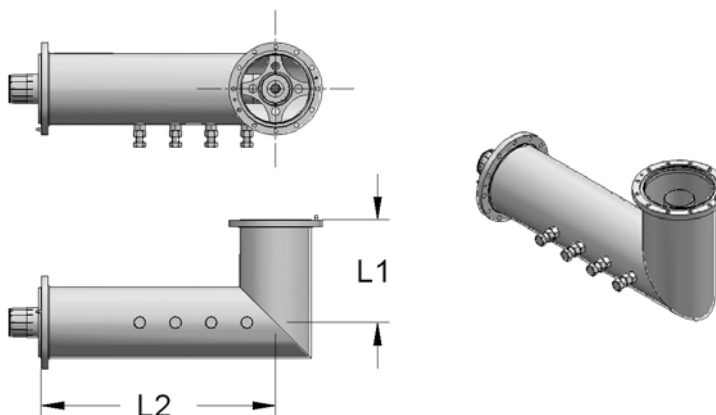

Specifications

Model Number	TUC1E-4	TUC3E-4	TUC4E-4	TUC6E-4
Input/output Connectors	1-5/8" EIA	3-1/8" EIA	4-1/16" FLG	6-1/8" EIA
Impedance	50 ohms	50 ohms	50 ohms	50 ohms
Outer Conductor	Aluminum	Aluminum	Aluminum	Aluminum
Tuning Screws	4	4	4	4

Frequency Range	470-860 MHz	470-860 MHz	470-860 MHz	470-766 MHz
Peak Voltage at Sea Level ¹	4 kV	7.8 kV	11 kV	15.6 kV
Average Power ²	≤ 5.4 kW	≤ 18 kW	≤ 28.7 kW	≤ 63.4 kW
Max. Altitude ³	10,000 feet (3,050 m)	10,000 feet (3,050 m)	10,000 feet (3,050 m)	10,000 feet (3,050 m)
Ambient Temperature	32°F (0°C) to 113°F (45°C)	32°F (0°C) to 113°F (45°C)	32°F (0°C) to 113°F (45°C)	32°F (0°C) to 113°F (45°C)
Storage Temperature	32°F (0°C) to 122°F (50°C)	32°F (0°C) to 122°F (50°C)	32°F (0°C) to 122°F (50°C)	32°F (0°C) to 122°F (50°C)
Storage/Ambient Humidity	0-98%, non condensing	0-98%, non condensing	0-98%, non condensing	0-98%, non condensing
Length (L1)	6" (152 mm)	6" (152 mm)	6" (152 mm)	9" (229 mm)
Length (L2)	12.25" (311 mm)	18" (457 mm)	20.5" (521 mm)	20.5" (521 mm)
Weight	6 lbs (2.7 kg)	8.6 lbs (4 kg)	13 lbs (6 kg)	17 lbs (7.8 kg)

Notes

- 1) Refers to 860MHz and at maximum capacitive load (with screws full screw in).
- 2) 860MHz (766MHz-6-1/8"EIA), 104°F (+40°C) ambient temperature, 145°F (63°C) outer temperature, 248°F (120°C) inner temperature sea level, 0 PSIG, VSWR=1.0
- 3) For more than 5,000 feet (1,524 m), please consult the factory.
- 4) Copper outers and voltage probes and/or directional couplers as part of the body of the tuning sections, are available upon request.

- Used to improve VSWR
- Indoor applications
- Available with 4 tuning screws

Specifications

Model Number	50013-21	50014-21	50015-21
Input/output Connectors	WR 1800	WR 1500	WR 1150
Impedance	50 ohms	50 ohms	50 ohms
Tuning Screws	4	4	4

Frequency Range	470-494 MHz	494-680 MHz	650-860 MHz
Peak Voltage at Sea Level ¹	225 kV	187 kV	144 kV
Max. Altitude ²	10,000 feet (3,050 m)	10,000 feet (3,050 m)	10,000 feet (3,050 m)
Ambient Temperature	32°F (0°C) to 113°F (45°C)	32°F (0°C) to 113°F (45°C)	32°F (0°C) to 113°F (45°C)
Storage Temperature	32°F (0°C) to 122°F (50°C)	32°F (0°C) to 122°F (50°C)	32°F (0°C) to 122°F (50°C)
Storage/Ambient Humidity	0-98, non condensing	0-98, non condensing	0-98, non condensing
Length	24" (610 mm)	24" (610 mm)	24" (610 mm)
Weight	40 lbs (18.1 kg)	25 lbs (11.3 kg)	17 lbs (7.7 kg)

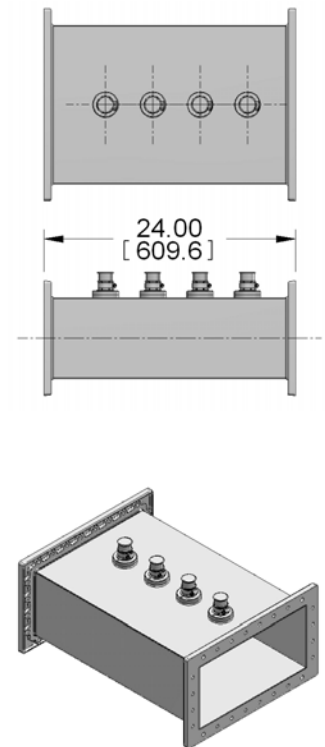

Notes

- 1) Refers to 860 MHz and at maximum capacitive load (with screws full screw in).
- 2) For more than 5,000 feet (1,524 m), please consult the factory.

- Used to measure FWD and RFL power
- Indoor applications
- Low VSWR
- High directivity

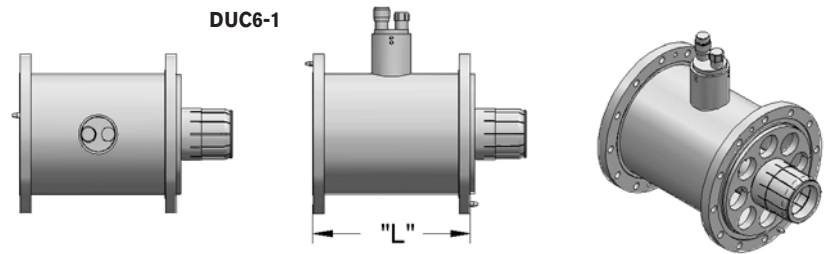

Specifications

Model Number	DUC716-1	DUC1-1	DUC3-1	DUC4-1	DUC6-1
Impedance	50 ohms	50 ohms	50 ohms	50 ohms	50 ohms
Frequency Range	470-860 MHz	54-860 Mhz	54-860 Mhz	54-860 Mhz	54-776 Mhz
Main Line Connectors	7/16" DIN M/F	1-5/8" EIA	3-1/8" EIA	4-1/16" FLG	6-1/8" EIA
Coupled Line Connectors¹	N	N	N	N	N
Peak Voltage at Sea Level	2 kV	4 kV	7.8 kV	11 kV	15.6 kW

Average Power²

108 MHz	N/A	≤ 15.1 kW	≤ 50.7 kW	≤ 80.9 kW	≤ 170.3 kW
230 MHz	N/A	≤ 10.4 kW	≤ 35.0 kW	≤ 55.8 kW	≤ 117.6 kW
776 MHz	≤ 1.1 kW	≤ 5.6 kW	≤ 18.9 kW	≤ 30.1 kW	≤ 63.4 kW

Coupling Range²

108 MHz	N/A	60 dB-50 dB	60 dB-50 dB	60 dB-50 dB	60 dB-50 dB
230 MHz	N/A	60 dB-50 dB	60 dB-50 dB	60 dB-50 dB	60 dB-50 dB
776 MHz	55 dB-36.5 dB	60 dB-45 dB	60 dB-45 dB	60 dB-45 dB	60 dB-45 dB

Max. Altitude³	10,000 feet (3,050 m)	10,000 feet (3,050 m)	10,000 feet (3,050 m)	10,000 feet (3,050 m)	10,000 feet (3,050 m)
Ambient Temperature	32°F (0°C) to 113°F (45°C)	32°F (0°C) to 113°F (45°C)	32°F (0°C) to 113°F (45°C)	32°F (0°C) to 113°F (45°C)	32°F (0°C) to 113°F (45°C)
Storage Temperature	32°F (0°C) to 122°F (50°C)	32°F (0°C) to 122°F (50°C)	32°F (0°C) to 122°F (50°C)	32°F (0°C) to 122°F (50°C)	32°F (0°C) to 122°F (50°C)
Storage/ Ambient Humidity	0-98%, non condensing	0-98%, non condensing	0-98%, non condensing	0-98%, non condensing	0-98%, non condensing
VSWR Main Line	≤ 1.02	≤ 1.02	≤ 1.02	≤ 1.02	≤ 1.02
VSWR Coupled Line	≤ 1.05	≤ 1.05	≤ 1.05	≤ 1.05	≤ 1.05
Directivity	> 30 dB	> 30 dB	> 30 dB	> 30 dB	> 30 dB
Insertion Loss	≤ 0.05 dB	≤ 0.05 dB	≤ 0.05 dB	≤ 0.05 dB	≤ 0.05 dB
Dimensions (L x H)	9" x 4.5" (228 mm x 114 mm)	6" (152.4 mm)	12" (305 mm)	12" (305 mm)	8" (152.4 mm)
Weight	Contact the factory	1.8 lbs (0.8 kg)	5.7 lbs (2.6 kg)	11 lbs (5 kg)	10.3 lbs (4.7 kg)

Notes

- 1) For other than 1 or 4 probes, please consult the factory
- 2) 104°F (40°C) ambient temperature, 248°F (120°C) outer temperature, sea level, 0 PSIG
- 3) For more than 5,000feet (1,524 m), please consult factory
- 4) Load on coupler must be sized for TPO vs. coupling value

- Used to measure FWD and RFL power
- Indoor applications
- Low VSWR
- High directivity

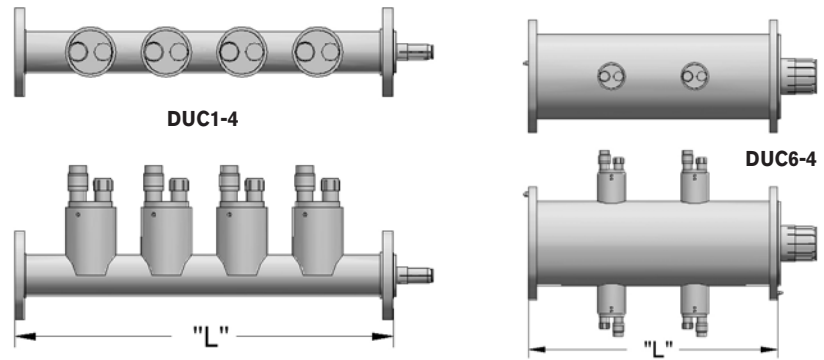

Specifications

Model Number	DUC716-4	DUC1-4	DUC3-4	DUC4-4	DUC6-4
Impedance	50 ohms	50 ohms	50 ohms	50 ohms	50 ohms
Frequency Range	470-860 MHz	54-860 Mhz	54-860 Mhz	54-860 Mhz	54-776 Mhz
Main Line Connectors	7/16" DIN M/F	1-5/8" EIA	3-1/8" EIA	4-1/16" FLG	6-1/8" EIA
Coupled Line Connectors¹	N	N	N	N	N
Peak Voltage at Sea Level	2 kV	4 kV	7.8 kV	11 kV	15.6 kV

Average Power²

108 MHz	≤ 3 kW	≤ 15.1 kW	≤ 50.7 kW	≤ 80.9 kW	≤ 170.3 kW
230 MHz	≤ 2.1 kW	≤ 10.4 kW	≤ 35.0 kW	≤ 55.8 kW	≤ 117.6 kW
776 MHz	≤ 1.1 kW	≤ 5.6 kW	≤ 18.9 kW	≤ 30.1 kW	≤ 63.4 kW

Coupling Range²

108 MHz	N/A	60 dB-50 dB	60 dB-50 dB	60 dB-50 dB	60 dB-50 dB
230 MHz	N/A	60 dB-50 dB	60 dB-50 dB	60 dB-50 dB	60 dB-50 dB
776 MHz	55 dB-36.5 dB	60 dB-45 dB	60 dB-45 dB	60 dB-45 dB	60 dB-45 dB

Max. Altitude³	10,000 feet (3,050 m)	10,000 feet (3,050 m)	10,000 feet (3,050 m)	10,000 feet (3,050 m)	10,000 feet (3,050 m)
Ambient Temperature	32°F (0°C) to 113°F (45°C)	32°F (0°C) to 113°F (45°C)	32°F (0°C) to 113°F (45°C)	32°F (0°C) to 113°F (45°C)	32°F (0°C) to 113°F (45°C)
Storage Temperature	32°F (0°C) to 122°F (50°C)	32°F (0°C) to 122°F (50°C)	32°F (0°C) to 122°F (50°C)	32°F (0°C) to 122°F (50°C)	32°F (0°C) to 122°F (50°C)
Storage/ Ambient Humidity	0-98%, non condensing	0-98%, non condensing	0-98%, non condensing	0-98%, non condensing	0-98%, non condensing
VSWR Main Line	≤ 1.02	≤ 1.02	≤ 1.02	≤ 1.02	≤ 1.02
VSWR Coupled Line	≤ 1.05	≤ 1.05	≤ 1.05	≤ 1.05	≤ 1.05
Directivity	> 30 dB	> 30 dB	> 30 dB	> 30 dB	> 30 dB
Insertion Loss	≤ 0.05 dB	≤ 0.05 dB	≤ 0.05 dB	≤ 0.05 dB	≤ 0.05 dB
Dimensions (L x H)	9" x 4.5" (228 mm x 114 mm)	15" (381 mm)	12" (305 mm)	12" (305 mm)	18" (457 mm)
Weight	Contact the factory	3.8 lbs (1.8 kg)	6.7 lbs (3.0 kg)	11.3 lbs (5.1 kg)	13.1 lbs (6 kg)

Notes

- 1) For other than 1 or 4 probes, please consult the factory
- 2) 104°F (40°C) ambient temperature, 248°F (120°C) outer temperature, sea level, 0 PSIG
- 3) For more than 5,000feet (1,524 m), please consult factory
- 4) Load on coupler must be sized for TPO vs. coupling value

- Used to measure FWD and RFL power
- Indoor applications
- Low VSWR
- High directivity

Specifications

Model Number	DU18-1	DU15-1	DU11-1
Impedance	50 ohms	50 ohms	50 ohms
Frequency Range	470-494 MHz	494-680 MHz	650-880 MHz
Main Line Connectors	WR 1800	WR 1500	WR 1150
Coupled Line Connectors¹	N	N	N
Peak Voltage at Sea Level	225 kV	187 kV	144 kV

Average Power²

494 MHz	≤ 1400 kW	N/A	N/A
650 MHz	N/A	≤ 650 kW	N/A
806 MHz	N/A	N/A	≤ 340 kW

Coupling Range²

494 MHz	40-70 dB	N/A	N/A
650 MHz	N/A	40-70 dB	N/A
806 MHz	N/A	N/A	40-70 dB

Max. Altitude³	10,000 feet (3,050 m)	10,000 feet (3,050 m)	10,000 feet (3,050 m)
Ambient Temperature	32°F (0°C) to 113°F (45°C)	32°F (0°C) to 113°F (45°C)	32°F (0°C) to 113°F (45°C)
Storage Temperature	32°F (0°C) to 122°F (50°C)	32°F (0°C) to 122°F (50°C)	32°F (0°C) to 122°F (50°C)
Storage/Ambient Humidity	0-98%, non condensing	0-98%, non condensing	0-98%, non condensing
VSWR Main Line	≤ 1.03	≤ 1.03	≤ 1.03
VSWR Coupled Line	≤ 1.05	≤ 1.05	≤ 1.05
Directivity	> 30 dB	> 30 dB	> 30 dB
Insertion Loss	≤ 0.1 dB	≤ 0.1 dB	≤ 0.1 dB
Dimensions (L)	12" (305 mm)	12" (305 mm)	12" (305 mm)
Weight	25.5 lbs (11.5 kg)	19.2 lbs (8.7 kg)	12.2 lbs (5.53 kg)

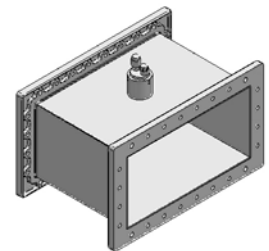
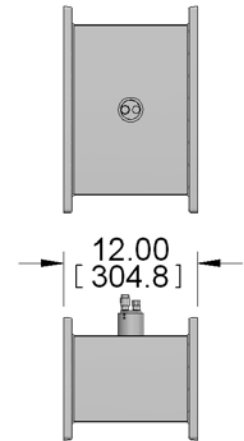

Notes

- 1) For other than 1 or 4 probes, please consult the factory
- 2) 104°F (+40°C) ambient temperature, sea level, 0 PSIG.
- 3) For more than 5,000 feet (1,524 m), please consult the factory.
- 4) Load on coupler must be sized for TPO vs. coupling value

- Used to measure FWD and RFL power
- Indoor applications
- Low VSWR
- High directivity

Specifications

Model Number	DU18-4	DU15-4	DU11-4
Impedance	50 ohms	50 ohms	50 ohms
Frequency Range	470-494 MHz	494-680 MHz	650-880 MHz
Main Line Connectors	WR 1800	WR 1500	WR 1150
Coupled Line Connectors¹	N	N	N
Peak Voltage at Sea Level	225 kV	187 kV	144 kV

Average Power²

494 MHz	≤ 1400 kW	N/A	N/A
650 MHz	N/A	≤ 650 kW	N/A
806 MHz	N/A	N/A	≤ 340 kW

Coupling Range²

494 MHz	40-70 dB	N/A	N/A
650 MHz	N/A	40-70 dB	N/A
806 MHz	N/A	N/A	40-70 dB

Max. Altitude³	10,000 feet (3,050 m)	10,000 feet (3,050 m)	10,000 feet (3,050 m)
Ambient Temperature	32°F (0°C) to 113°F (45°C)	32°F (0°C) to 113°F (45°C)	32°F (0°C) to 113°F (45°C)
Storage Temperature	32°F (0°C) to 122°F (50°C)	32°F (0°C) to 122°F (50°C)	32°F (0°C) to 122°F (50°C)
Storage/Ambient Humidity	0-98%, non condensing	0-98%, non condensing	0-98%, non condensing
VSWR Main Line	≤ 1.03	≤ 1.03	≤ 1.03
VSWR Coupled Line	≤ 1.05	≤ 1.05	≤ 1.05
Directivity	> 30 dB	> 30 dB	> 30 dB
Insertion Loss	≤ 0.1 dB	≤ 0.1 dB	≤ 0.1 dB
Dimensions (L)	18" (457 mm)	18" (457 mm)	18" (457 mm)
Weight	32 lbs (14.5 kg)	19.8 lbs (9.0 kg)	15.2 lbs (6.7 kg)

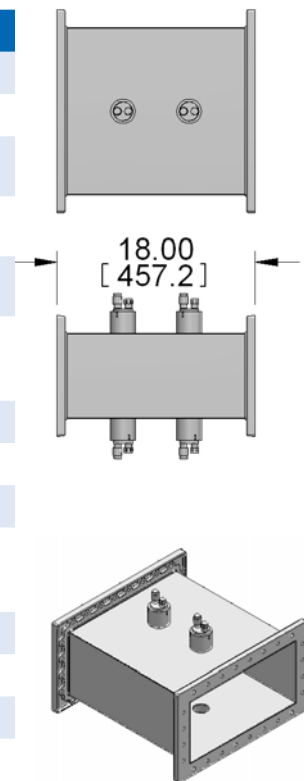

Notes

- 1) For other than 1 or 4 probes, please consult the factory
- 2) 104°F (+40°C) ambient temperature, sea level, 0 PSIG.
- 3) For more than 5,000 feet (1,524 m), please consult the factory.
- 4) Load on coupler must be sized for TPO vs. coupling value

Dielectric® Standard Coaxial Flanged Reducers¹

- Low insertion loss (< 0.05 dB)
- Low VSWR (≤ 1.05)
- Indoor/outdoor applications

Specifications

Model Number	Connector #1	Connector#2 ²	Length	Weight
DC 275-063	1-5/8" EIA	"N"-F	2.19" (56 mm)	2 lbs (0.9 kg)
DC 275-062	1-5/8" EIA	"N"-M	2.19" (56 mm)	2 lbs (0.9 kg)
DC 275-060	1-5/8" EIA	7/8" EIA	1.74" (44 mm)	2 lbs (0.9 kg)

DC 375-063	3-1/8" EIA	"N"-F	1.75" (44.5 mm)	3 lbs (1.36 kg)
DC 375-062	3-1/8" EIA	"N"-M	1.75" (44.5 mm)	3 lbs (1.36 kg)
DC 375-061	3-1/8" EIA	7/8" EIA	1.25" (31.8 mm)	5 lbs (2.27 kg)
DC 375-060	3-1/8" EIA	1-5/8" EIA	0.875" (22 mm)	6 lbs (2.72 kg)

DC 475-063	4-1/16" FLG	"N"-F	1.87" (47.5 mm)	4 lbs (1.8 kg)
DC 475-060	4-1/16" FLG	3-1/8" EIA	4.00" (101.6 mm)	10 lbs (4.5 kg)

DC 675-061	6-1/8" EIA	3-1/8" EIA	6.75" (171.5 mm)	14 lbs (6.35 kg)
DC 675-060	6-1/8" EIA	4-1/16" FLG	5.00" (127 mm)	16 lbs (7.26 kg)

Notes

- 1) For custom reducers or other size than the standard list, please consult the factory.
- 2) Reducers on the smaller size includes an Anchor Inner Connector, "O" ring and hardware.

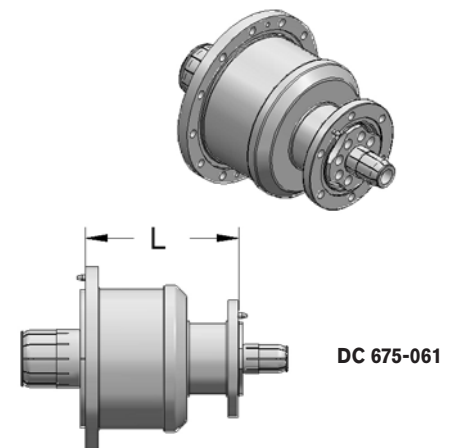
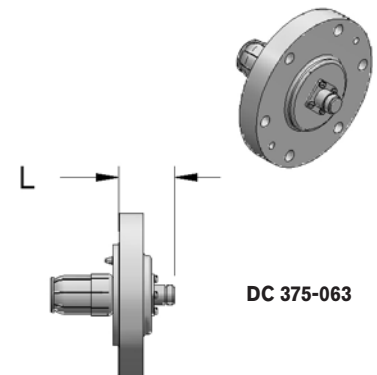

- Used to facilitate WR to coaxial transition
- Indoor applications

Specifications

Impedance	50 ohms
Frequency Range	$470 \leq F \leq 494$ MHz
Ambient Temperature	32°F to 113°F (0°C to 45°C)
Storage Temperature	32°F to 122°F (0°C to 50°C)
Storage/Ambient Humidity	0-98%, non condensing
Max. Altitude¹	10,000 feet (3,050 m)
VSWR²	< 1.1

Model Number	W18-1	W18-3	W18-4	W18-6
WR 1800 to Coaxial	1-5/8" EIA	3-1/8" EIA	4-1/16" FLG	6-1/8" EIA
Peak Voltage at Sea Level	4 kV	7.8 kV	11 kV	15.6 kV
Peak Power at Sea Level	320 kW	1,216.8 kW	2,420 kW	4,867.2 kW
Weight	21.1 lbs (9.6 kg)	22.1 lbs (10 kg)	23.1 lbs (10.5 kg)	25.1 lbs (11.4 kg)

Notes

- 1) For more than 5,000 feet (1,524 m), please consult the factory.
- 2) 104°F (40°C) ambient temperature, sea level, 0 PSIG.
- 3) Maximum average power handling is equal with the one of the coaxial line's size.

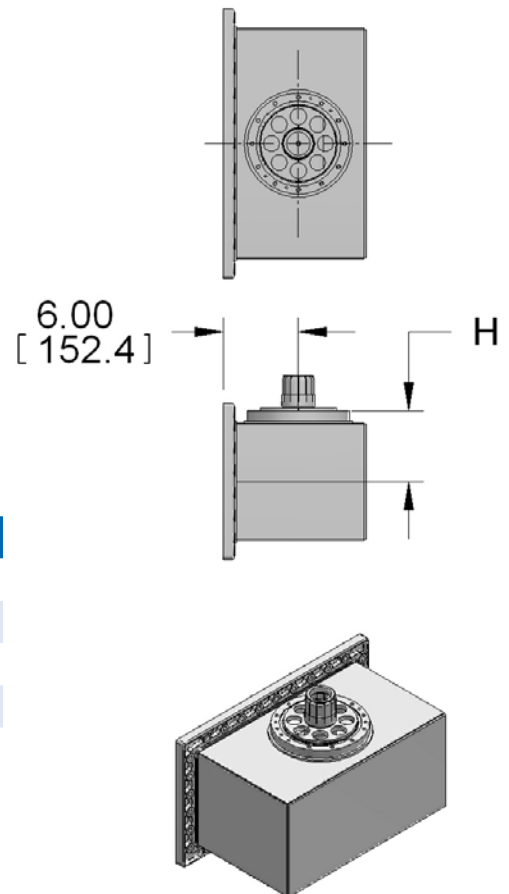

- Used to facilitate WR to coaxial transition
- Indoor applications

Specifications

Impedance	50 ohms
Frequency Range	$494 \leq F \leq 680$ MHz
Ambient Temperature	32°F to 113°F (0°C to 45°C)
Storage Temperature	32°F to 122°F (0°C to 50°C)
Storage/Ambient Humidity	0-98%, non condensing
Max. Altitude¹	10,000 feet (3,050 m)
VSWR²	< 1.1

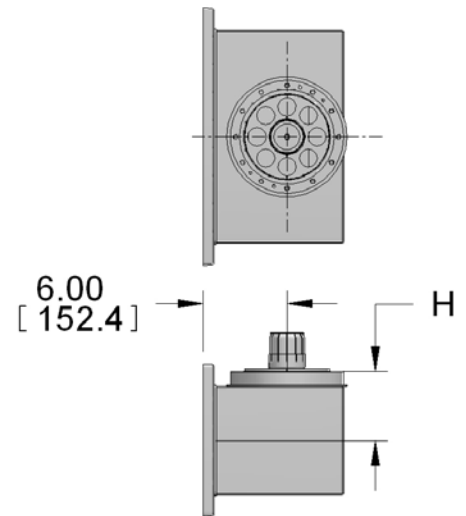

Model Number	W15-1	W15-3	W15-4	W15-6
WR 1500 to Coaxial	1-5/8" EIA	3-1/8" EIA	4-1/16" FLG	6-1/8" EIA
Peak Voltage at Sea Level	4 kV	7.8 kV	11 kV	15.6 kV
Peak Power at Sea Level	320 kW	1,216.8 kW	2,420 kW	4,867.2 kW
Weight	12 lbs (5.5 kg)	13.8 lbs (6.3 kg)	14.8 lbs (6.7 kg)	16.8 lbs (7.6 kg)

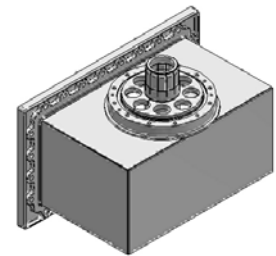

Notes

- 1) For more than 5,000 feet (1,524 m), please consult the factory.
- 2) 104°F (40°C) ambient temperature, sea level, 0 PSIG.
- 3) Maximum average power handling is equal with the one of the coaxial line's size.

- Used to facilitate WR to coaxial transition
- Indoor applications

Specifications

Impedance	50 ohms
Frequency Range	$650 \leq F \leq 880$ MHz
Ambient Temperature	32°F to 113°F (0°C to 45°C)
Storage Temperature	32°F to 122°F (0°C to 50°C)
Storage/Ambient Humidity	0-98%, non condensing
Max. Altitude¹	10,000 feet (3,050 m)
VSWR²	< 1.1

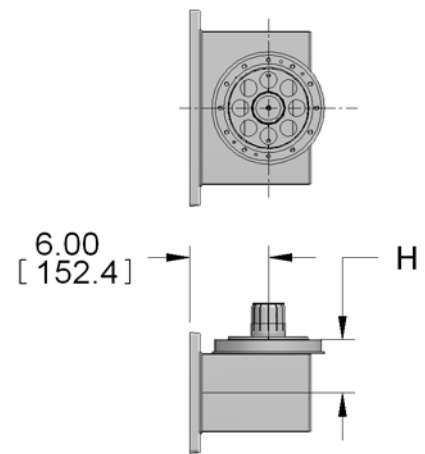

Model Number	W11-1	W11-3	W11-4	W11-6
WR 1150 to Coaxial	1-5/8" EIA	3-1/8" EIA	4-1/16" FLG	6-1/8" EIA ⁴
Peak Voltage at Sea Level	4 kV	7.8 kV	11 kV	15.6 kV
Peak Power at Sea Level	320 kW	1,216.8 kW	2,420 kW	4,867.2 kW
Weight	9.5 lbs (4.3 kg)	10.7 lbs (4.9 kg)	11.8 lbs (5.4 kg)	13.7 lbs (6.2 kg)

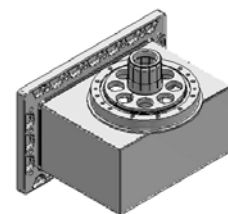

Notes

- 1) For more than 5,000 feet (1,524 m), please consult the factory.
- 2) 104°F (40°C) ambient temperature, sea level, 0 PSIG.
- 3) Maximum average power handling is equal with the one of the coaxial line's size.
- 4) Maximum frequency available is 776 MHz.

Specifications

Model Number	LLU60K6
Input/output connectors¹	6-1/8" EIA
Impedance	50 ohms
Tuning screws	N/A
Frequency Range	470-806 Mhz
Average Power at Sea Level²	Same as input line size rating
Operating Position	Horizontal; water outlet up
Cooling Method³	Forced mixture of 50/50 water-ethylene glycol
Inlet Water Pressure (Max.)	80 psi (5.4 atm)
Inlet Water Temperature⁴	102°F to 131°F (39°C to 55°C)
Outlet Water Temperature (Max.)	194°F (90°C)
Inlet/Outlet Water Connectors	1" NTP
Max. Altitude⁵	10,000 feet (3,050 m)
Ambient Temperature	41°F (5°C) to 113°F (45°C)
Storage Temperature	32°F (0°C) to 122°F (50°C)
Storage/Ambient Humidity	0-98%, non condensing
Length	37" (940 mm)
Weight	40 lbs (18.1 kg)

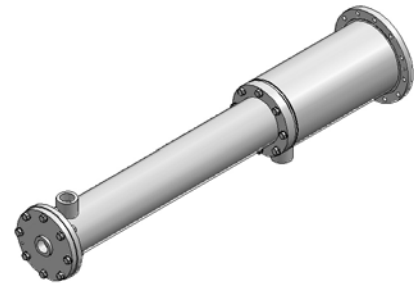
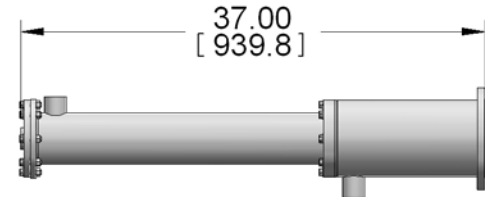

Notes

- 1) 3-1/8" EIA model #LLU20K3, and 4-1/16" FLG model #LLU30K4 sizes available upon request. Body of load is 4" and will operate to frequencies above 6" line size, limit.
- 2) At 766 Mhz, 77°F (25°C) ambient, sea level, 0 PSIG
- 3) Euchatorm or Dowtherm SR-1, or echivalent mixture
- 4) Recommended; With Inlet Glycol/Water temperature within allowable listed above, produce flow sufficient to maintain <54°F (30°C) rise in fluid. Flows estimates 10 gallons for 80 kW, 15 gallons for 100 kW and 20 gallons for 150 kW.
- 5) For more than 5,000' (1,524 m) please consult the factory

An emergency drain has been provided to allow flow in case of a seal failure into the load. A hose must be attached by the user to route that flow to an appropriate drain.

Specifications

Model Number	LLU200K18	LLU200K15	LLU200K11
Input/output connectors	WR 1800	WR 1500	WR 1150
Impedance	N/A	N/A	N/A
Tuning screws	4	4	4

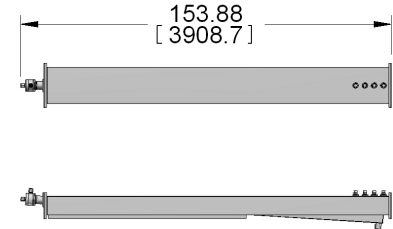

Frequency Range	470-494 Mhz	494-680 Mhz	650-880 Mhz
Average Power at Sea Level ¹	200 kW	200 kW	200 kW
Operating Position	Horizontal; water outlet up	Horizontal; water outlet up	Horizontal; water outlet up
Cooling Method ²	Forced mixture of 50/50 water-ethylene glycol	Forced mixture of 50/50 water-ethylene glycol	Forced mixture of 50/50 water-ethylene glycol
Inlet Water Pressure (Max.)	50 psi (3.4 atm)	50 psi (3.4 atm)	50 psi (3.4 atm)
Inlet Water Temperature ³	102°F to 131°F (39°C to 55°C)	102°F to 131°F (39°C to 55°C)	102°F to 131°F (39°C to 55°C)
Outlet Water Temperature (Max.)	194°F (90°C)	194°F (90°C)	194°F (90°C)
Inlet/Outlet Water Connectors	1" NTP	1" NTP	1" NTP
Max. Altitude ⁴	10,000 feet (3,050 m)	10,000 feet (3,050 m)	10,000 feet (3,050 m)
Ambient Temperature	32°F (0°C) to 113°F (45°C)	32°F (0°C) to 113°F (45°C)	32°F (0°C) to 113°F (45°C)
Storage Temperature	32°F (0°C) to 122°F (50°C)	32°F (0°C) to 122°F (50°C)	32°F (0°C) to 122°F (50°C)
Storage/Ambient Humidity	0-98%, non condensing	0-98%, non condensing	0-98%, non condensing
Length	154" (3900 mm)	154" (3900 mm)	154" (3900 mm)
Weight	215 lbs (97.5 kg)	185 lbs (84 kg)	155 lbs (70.3 kg)

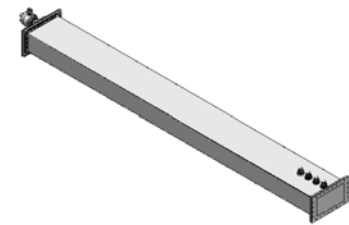

Notes

- 3-1/8"EIA model #LLU20K3, and 4-1/16"FLNG model #LLU30K4 sizes available upon request. Body of load is 4" and will operate to frequencies above 6" line size, limit.
- At 766 Mhz, 77°F (25°C) ambient, sea level, 0 PSIG
- Euchaterm or Dowtherm SR-1, or equivalent mixture
- Recommended; With Inlet Glycol/Water temperature within allowable listed above, produce flow sufficient to maintain <54°F (30°C) rise in fluid. Flows estimates 10 gallons for 80 kW, 15 gallons for 100 kW and 20 gallons for 150 kW.
- For more than 5,000 Ft. (1,524 m) please consult the factory

An emergency drain has been provided to allow flow in case of a seal failure into the load. A hose must be attached by the user to route that flow to an appropriate drain.

Dielectric products are represented in 90 countries around the world. With the rapid expansion of communications, Dielectric is positioned to service the broadcast needs of small and large stations, DTV and NTSC, FM and specialty RF systems, complete systems and components.



Abu Dhabi	Guatemala	Papua New Guinea
Angola	Hong Kong	Peru
Argentina	Iceland	Philippines
Australia	India	Poland
Austria	Indonesia	Portugal
Belgium	Ireland	Puerto Rico
Belize	Israel	Qatar
Benin	Italy	Romania
Botswana	Japan	Russia
Brazil	Jordan	Saipan
Canada	Korea	Sao Tome
Chad	Kuwait	Saudi Arabia
Chile	Lebanon	Singapore
China	Liberia	South Africa
Colombia	Madagascar	Spain
Costa Rica	Malaysia	Sri Lanka
Denmark	Mali	Sweden
Dominican Republic	Malta	Switzerland
Ecuador	Mauritania	Syria
Egypt	Mauritius	Taiwan
Elbonia	Mexico	Thailand
El Salvador	Mongolia	Togo
England	Morocco	Trinidad
Ethiopia	Nepal	Uganda
Finland	Netherlands	United States
France	New Zealand	Venezuela
Germany	Nicaragua	Vietnam
Ghana	Nigeria	Yemen
Greece	Norway	Zambia
Greenland	Oman	Zimbabwe
Guam	Pakistan	